



Stainless Steel FRLs

Air Preparation Units

Catalog 0300



 **WARNING**

FAILURE, IMPROPER SELECTION OR IMPROPER USE OF THE PRODUCTS AND/OR SYSTEMS DESCRIBED HEREIN OR RELATED ITEMS CAN CAUSE DEATH, PERSONAL INJURY AND PROPERTY DAMAGE.

This document and other information from The Company, its subsidiaries and authorized distributors provide product and/or system options for further investigation by users having technical expertise. It is important that you analyze all aspects of your application, and review the information concerning the product or system in the current product catalog. Due to the variety of operating conditions and applications for these products or systems, the user, through its own analysis and testing, is solely responsible for making the final selection of the products and systems and assuring that all performance, safety and warning requirements of the application are met.

The products described herein, including without limitation, product features, specifications, designs, availability and pricing, are subject to change by The Company and its subsidiaries at any time without notice.

Offer of Sale

The items described in this document are hereby offered for sale by The Company, its subsidiaries or its authorized distributors. This offer and its acceptance are governed by the provisions stated on the separate page of this document entitled "Offer of Sale".

© Copyright 2003, 2005 Parker Hannifin Corporation. All Rights Reserved.



Pneumatic Division
Richland, Michigan
www.wattsfluidair.com

Air Line Filters

Miniature F504	2-3
Standard F10	4-5

Air Line Coalescing Filters

Miniature F501	6-7
Standard F11	8-9

Air Line Regulators

Miniature R364	10-11
Miniature R354	12-13
Standard R10	14-15

Filter / Regulator "Piggybacks"

Miniature B548	16-17
Miniature B558	18-19
Standard B11	20-21

Air Line Lubricators

Standard L10	22-23
--------------------	-------

Offer of Sale	25
---------------------	----

F504 Filter – Miniature

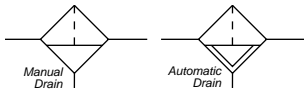

Features

- Stainless Steel Construction Handles Most Corrosive Environments
- Fluorocarbon Seals Standard
- Meets NACE Specifications
- High Flow: 1/4" – 23 SCFM[§]

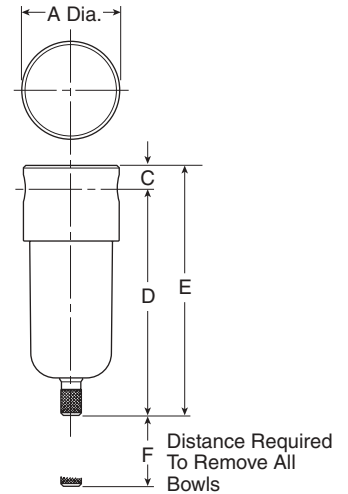

Port Size	NPT	BSP
	Manual Twist Drain	Manual Twist Drain
1/4"	F504-02DHSS	F504G02DHSS

F504 Filter Dimensions		
A	C	D
1.56 (40)	0.31 (8)	3.69 (94)
E	F	
4.00 (102)	1.58 (40)	

Standard part numbers shown bold. For other models refer to ordering information below.
[§] SCFM = Standard cubic feet per minute at 90 PSIG inlet and 5 PSIG pressure drop.

inches
(mm)

Ordering Information

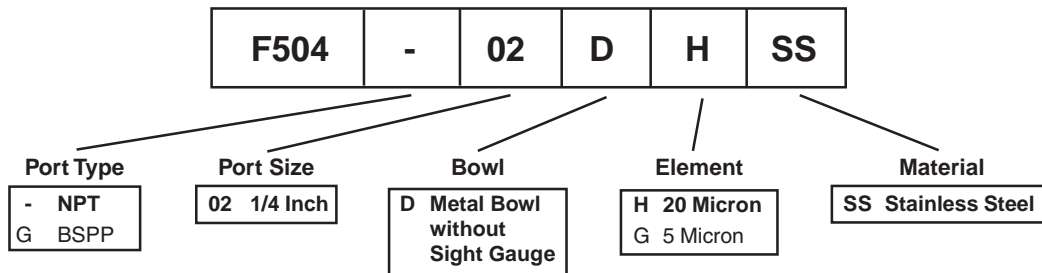

NOTE: BOLD ITEMS ARE STANDARD.

Operation

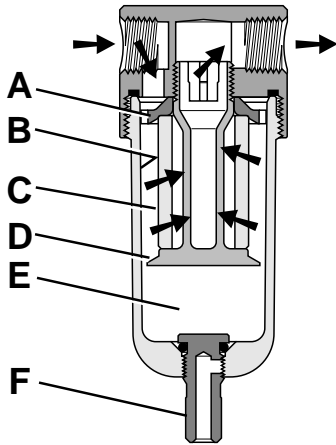

First Stage Filtration:

Air enters at inlet port and flows through deflector plate (A) which causes a swirling action. Liquids and coarse particles are forced to the bowl interior wall (B) by the centrifugal action of the swirling air. They are then carried down the bowl wall by the force of gravity. The baffle (D) separates the lower portion of the bowl into a “quiet zone” (E) where the removed liquid and particles collect, unaffected by the swirling air, and are therefore not reentrained into the flowing air.

Second Stage Filtration:

After liquids and large particles are removed in the first stages of filtration, the air flows through element (C) where smaller particles are filtered out. The filtered air then passes downstream. Collected liquids and particles in the “quiet zone” (E) should be drained before their level reaches a height where they would be reentrained in the flowing air. This can be accomplished by unscrewing the drain valve (F) slightly until the liquid begins to drain.

Technical Information

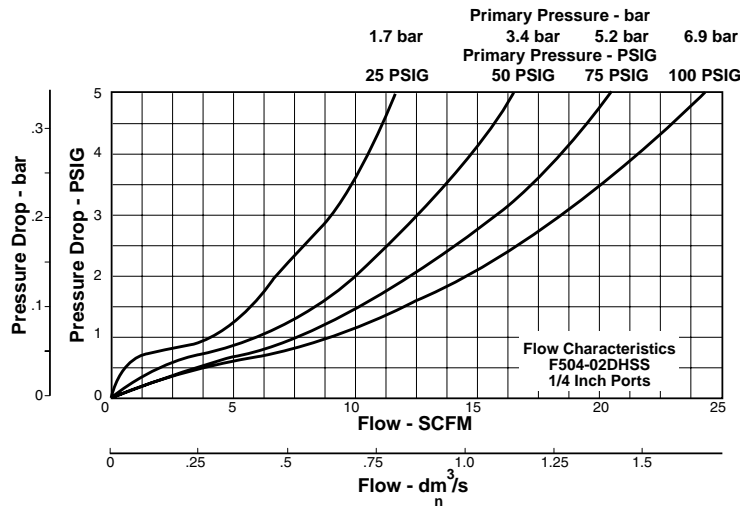

F504 Filter Kits & Accessories

- Filter Element Kits –
 - Particulate (5 Micron) EK504VY
 - Particulate (20 Micron) EK504Y
- Manual Twist Drain SA600Y7-1SS
- Pipe Nipple –
 - 1/4" 316 Stainless Steel 616Y28-SS

Specifications

- Bowl Capacity 1.0 Ounces
- Filter Rating 20 Micron
- Sump Capacity 0.4 Ounce
- Port Threads 1/4 Inch

Pressure & Temperature Ratings –

Manual Twist Drain 0 to 300 PSIG (0 to 20.7 bar)
40°F to 180°F (4°C to 82°C)

Weight 0.6 lb. (0.27 kg)

Materials of Construction

- Body 316 Stainless Steel
- Bowls 316 Stainless Steel
- Deflector Acetal
- Drain 316 Stainless Steel
- Element Holder Acetal
- Filter Element Polyethylene
- Seals Fluorocarbon

F10 Filter – Standard

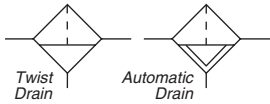

Features

- Stainless Steel Construction Handles Most Corrosive Environments
- Meets NACE Specifications
- High Flow: 1/2" – 70 SCFM[§]

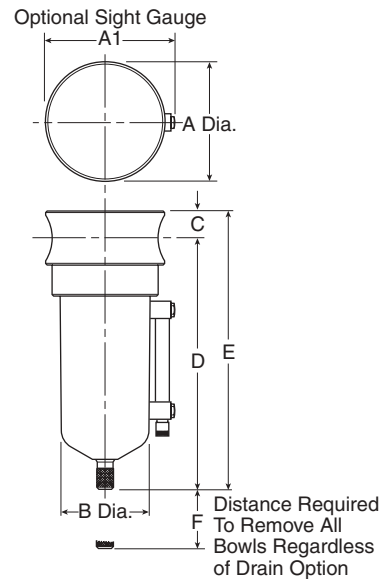

Port Size	NPT		BSPP	
	Manual Twist Drain	Automatic Float Drain	Manual Twist Drain	Automatic Float Drain
1/2"	F10-04DJSS	F10-04DJRSS	F10G04DJSS	F10G04DJRSS

Standard part numbers shown bold. For other models refer to ordering information below.
[§] SCFM = Standard cubic feet per minute at 90 PSIG inlet and 5 PSIG pressure drop.

F10 Filter Dimensions		
A 2.38 (60)	A₁ 2.50 (64)	B 1.75 (44)
C .56 (14)	D 5.00 (127)	E 5.56 (141)
F 2.12 (54)		

inches
(mm)

Ordering Information

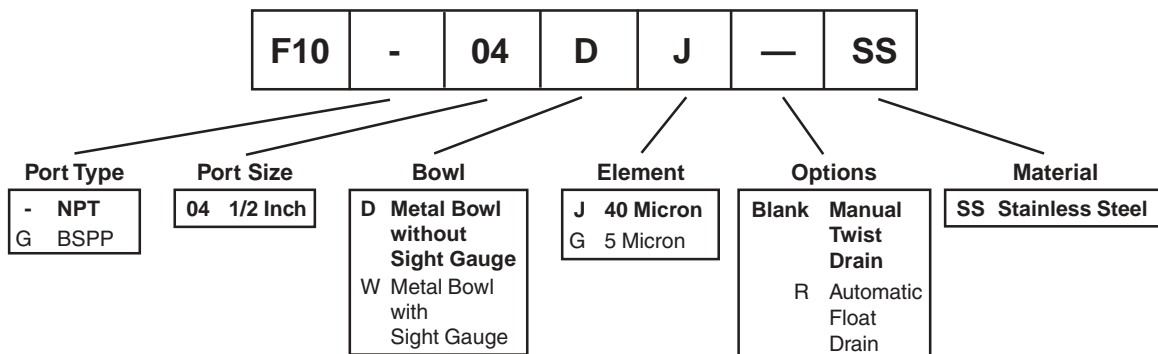

NOTE: BOLD ITEMS ARE STANDARD.

Operation

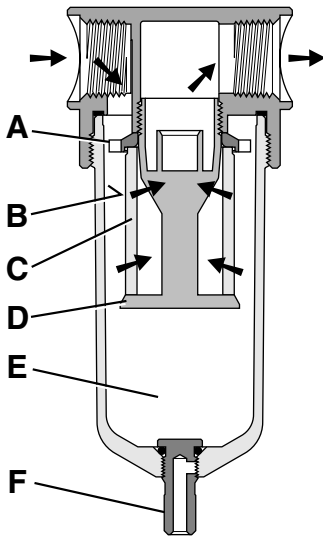

First Stage Filtration:

Air enters at inlet port and flows through deflector plate (A) which causes a swirling action. Liquids and coarse particles are forced to the bowl interior wall (B) by the centrifugal action of the swirling air. They are then carried down the bowl wall by the force of gravity. The baffle (D) separates the lower portion of the bowl into a “quiet zone” (E) where the removed liquid and particles collect, unaffected by the swirling air, and are therefore not reentrained into the flowing air.

Second Stage Filtration:

After liquids and large particles are removed in the first stages of filtration, the air flows through element (C) where smaller particles are filtered out. The filtered air then passes downstream. Collected liquids and particles in the “quiet zone” (E) should be drained before their level reaches a height where they would be reentrained in the flowing air. This can be accomplished by unscrewing the drain valve (F) slightly until the liquid begins to drain.

Technical Information

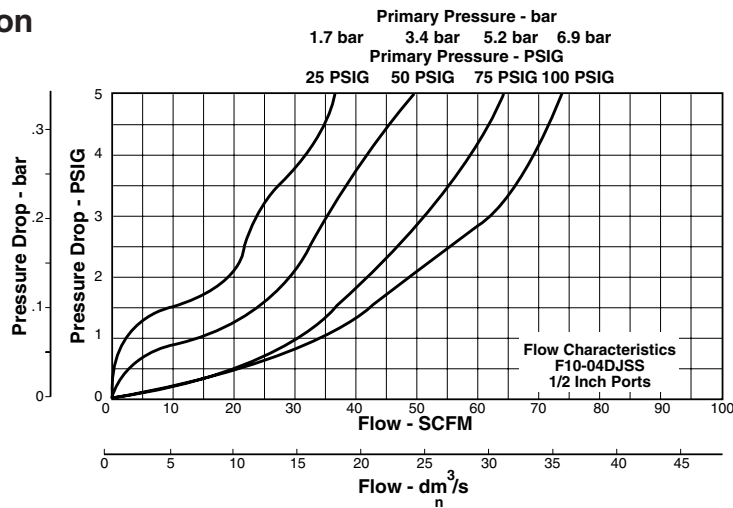

F10 Filter Kits & Accessories

- Drain Kit –**
 Automatic Float Drain SA602MDSS
 Manual Twist Drain SA600Y7-1SS
- Filter Element Kits –**
 Particulate (40 Micron) EK55J
 Particulate (5 Micron) EK55G
- Pipe Nipple – 1/2" 316 Stainless Steel 616A28-SS**

Specifications

- Bowl Capacity 4.0 Ounces**
Filter Rating 40 Micron
Sump Capacity 1.7 Ounce
Port Threads 1/2 Inch

Pressure & Temperature Ratings –

- Manual Twist Drain (D) 0 to 300 PSIG (0 to 20.7 bar)
 40°F to 180°F (4°C to 82°C)
- Manual Twist Drain (W) 0 to 250 PSIG (0 to 17.2 bar)
 40°F to 150°F (4°C to 66°C)
- Automatic Float Drain 15 to 175 PSIG (1 to 12 bar)
 40°F to 125°F (4°C to 52°C)

Weight 1.9 lb. (0.85 kg)

Materials of Construction

- Body 316 Stainless Steel**
Bowls 316 Stainless Steel
Deflector Acetal
Drain 316 Stainless Steel
Element Holder Acetal
Filter Element Polyethylene
Seals Fluorocarbon
Sight Gauge Isoplast

F501 Coalescing Filter – Miniature

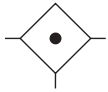

Features

- Stainless Steel Construction Handles Most Corrosive Environments
- Meets NACE Specifications
- High Flow: 1/4" – 16 SCFM[§]

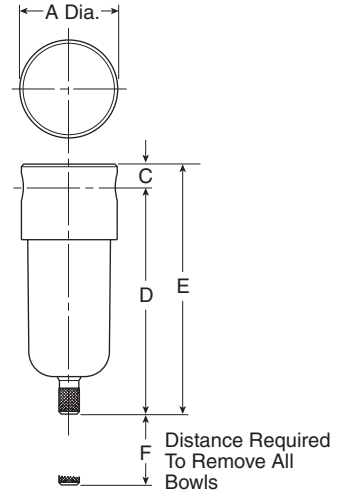

Port Size	NPT	BSP
	Manual Twist Drain	Manual Twist Drain
1/4"	F501-02DHSS	F501G02DHSS

F501 Coalescing Filter Dimensions		
A	C	D
1.56 (40)	0.31 (8)	3.69 (94)
E	F	
4.00 (102)	1.58 (40)	

Standard part numbers shown bold. For other models refer to ordering information below.
[§] SCFM = Standard cubic feet per minute at 90 PSIG inlet and 5 PSIG pressure drop.

inches
(mm)

Ordering Information

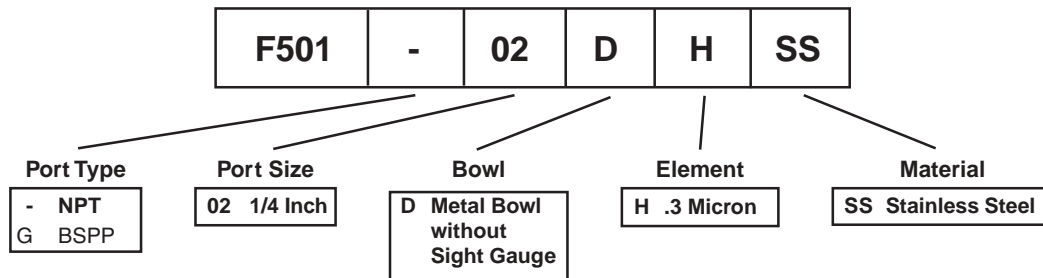

NOTE: BOLD ITEMS ARE STANDARD.

Operation

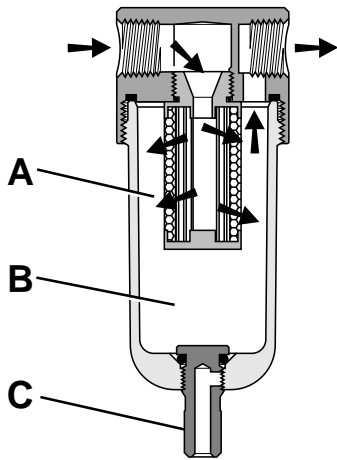

The contaminated air enters the element interior and is forced through a thick membrane (A) of “borosilicate” glass fibers coated with epoxy. Flow then passes through the element, and at this stage 99.97% of the sub micron particles have been removed from the air stream. The tiny droplets coalesce together and are collected from the filter element by the outer drain layer.

The clean, filtered air now passes through and out into the pneumatic system. The air line coalescing filter removes liquid aerosols and sub-micron particulate matter.

Collected liquids and particles in the “quiet zone” (B) should be drained before their level reaches a height where they would be reentrained in the flowing air. This can be accomplished by unscrewing the drain valve (C) slightly until the liquid begins to drain.

Technical Information

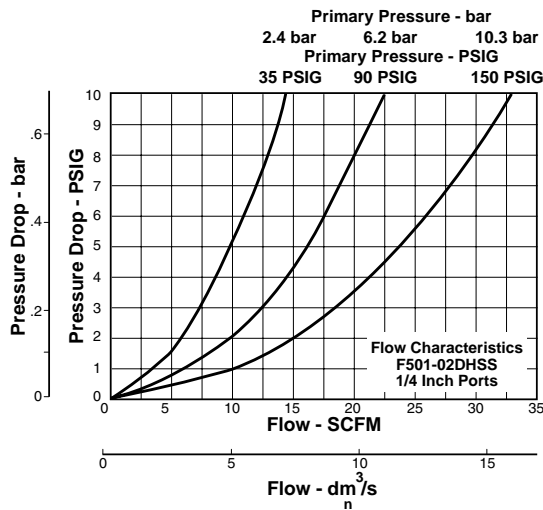

F501 Filter Kits & Accessories

- Filter Element Kits –
 - 0.3 Micron EKF501H
- Manual Twist Drain SA600Y7-1SS
- Pipe Nipple –
 - 1/4" 316 Stainless Steel 616Y28-SS

Specifications

- Bowl Capacity 1.0 Ounces
- Filter Rating 0.3 Micron
- Port Threads 1/4 Inch

Pressure & Temperature Ratings –

- Manual Twist Drain 0 to 300 PSIG (0 to 20.7 bar)
40°F to 180°F (4°C to 82°C)

- Sump Capacity 0.4 Ounce
- Weight 0.6 lb. (0.27 kg)

Materials of Construction

- Body 316 Stainless Steel
- Bowls 316 Stainless Steel
- Drain 316 Stainless Steel
- Element Holder Acetal
- Filter Element Borosilicate Fiber
- Seals Fluorocarbon

F11 Coalescing Filter – Standard

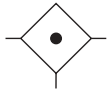

Features

- Stainless Steel Construction Handles Most Corrosive Environments
- Meets NACE Specifications
- High Flow: 1/2" – 45 SCFM[§]

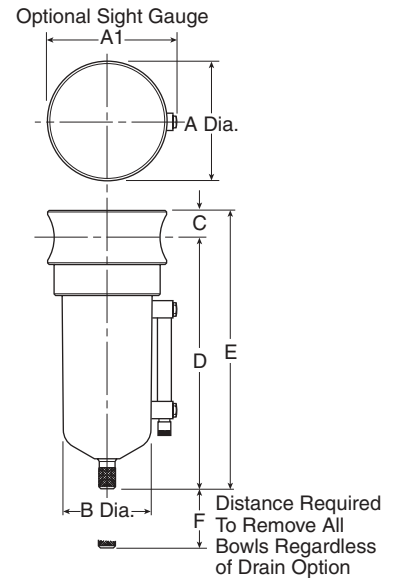

Port Size	NPT		BSPP	
	Manual Twist Drain	Automatic Float Drain	Manual Twist Drain	Automatic Float Drain
1/2"	F11-04DJSS	F11-04DJRSS	F11G04DJSS	F11G04DJRSS

Standard part numbers shown bold. For other models refer to ordering information below.

[§] SCFM = Standard cubic feet per minute at 90 PSIG inlet and 5 PSIG pressure drop.

F11 Coalescing Filter Dimensions		
A 2.38 (60)	A₁ 2.50 (64)	B 1.75 (44)
C 0.56 (14)	D 5.00 (127)	E 5.56 (141)
F 2.12 (54)		

inches
(mm)

Ordering Information

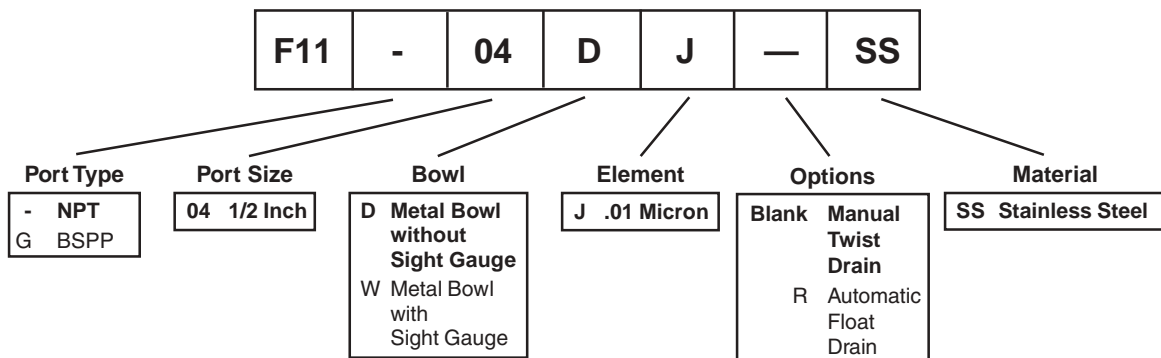

NOTE: BOLD ITEMS ARE STANDARD.

Operation

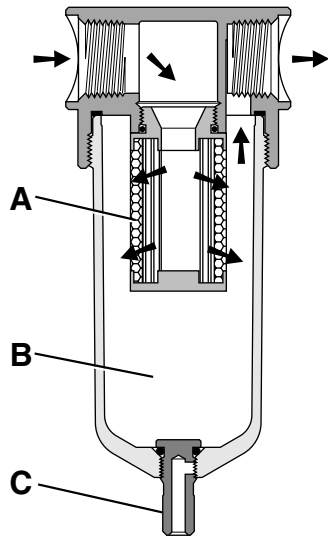

The contaminated air enters the element interior and is forced through a thick membrane (A) of “borosilicate” glass fibers coated with epoxy. Flow then passes through the element, and at this stage 99.97% of the sub micron particles have been removed from the air stream. The tiny droplets coalesce together and are collected from the filter element by the outer drain layer.

The clean, filtered air now passes through and out into the pneumatic system. The air line coalescing filter removes liquid aerosols and sub-micron particulate matter.

Collected liquids and particles in the “quiet zone” (B) should be drained before their level reaches a height where they would be reentrained in the flowing air. This can be accomplished by unscrewing the drain valve (C) slightly until the liquid begins to drain.

Technical Information

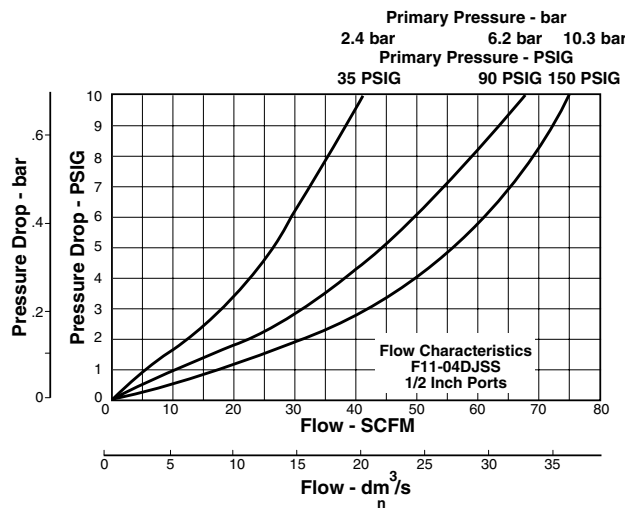

F11 Filter Kits & Accessories

- Drain Kit –**
 Automatic Float Drain SA602MDSS
 Manual Twist Drain SA600Y7-1SS
- Filter Element Kits –**
 0.3 Micron EKF71
- Pipe Nipple –**
 1/2" 316 Stainless Steel 616A28-SS

Pressure & Temperature Ratings –

- Manual Twist Drain 0 to 300 PSIG (0 to 20.7 bar)
 40°F to 180°F (4°C to 82°C)
- Manual Twist Drain (W) 0 to 250 PSIG (0 to 17.2 bar)
 40°F to 150°F (4°C to 66°C)
- Automatic Float Drain 0 to 175 PSIG (0 to 12 bar)
 40°F to 125°F (4°C to 52°C)

Weight 1.9 lb. (0.85 kg)

Specifications

- Bowl Capacity** 4.0 Ounces
- Filter Rating** 0.01 Micron
- Sump Capacity** 1.7 Ounce
- Port Threads** 1/2 Inch

Materials of Construction

- Body** 316 Stainless Steel
- Bowls** 316 Stainless Steel
- Drain** 316 Stainless Steel
- Element Holder** Acetal
- Filter Element** Borosilicate Fiber
- Seals** Fluorocarbon
- Sight Gauge** Isoplast

R364 Regulator – Miniature

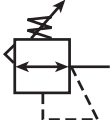

Features

- Stainless Steel Construction Handles Most Corrosive Environments
- Large Diaphragm to Valve Area Ratio for Precise Regulation and High Flow Capacity
- Meets NACE Specifications
- High Flow: 1/4" – 12 SCFM[§]

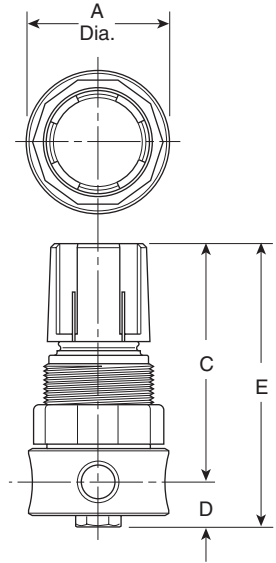

Port Size	NPT	BSPP
1/4"	R364-02CSS	R364G02CSS

R364 Regulator Dimensions		
A	C	D
1.56 (40)	2.56 (65)	0.50 (13)
E		
3.06 (78)		

Standard part numbers shown bold. For other models refer to ordering information below.

[§] SCFM = Standard cubic feet per minute at 100 PSIG inlet, 75 PSIG no flow secondary setting and 125% pressure drop.

⚠ WARNING

Do not connect regulator to bottled gas.
 Do not exceed maximum primary pressure rating.
 Product rupture can cause serious injury.

inches
(mm)

NOTE: 1.25 Dia. (32mm) hole required for panel mounting.

Ordering Information

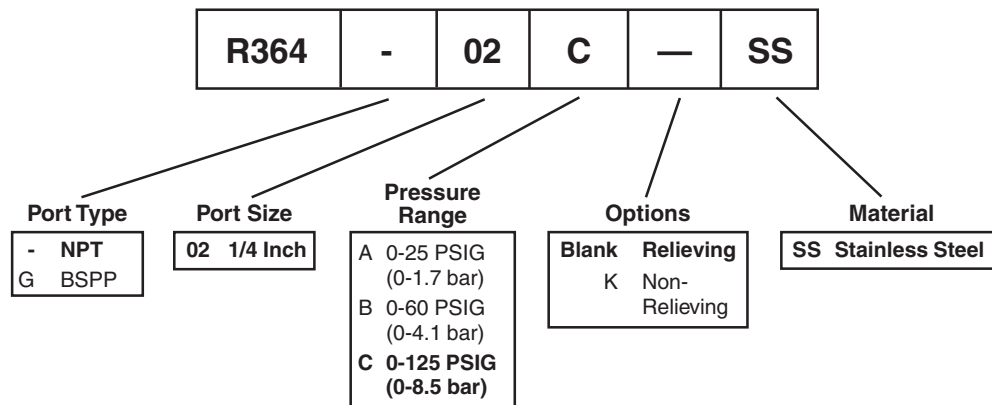

NOTE: BOLD ITEMS ARE STANDARD.

Operation

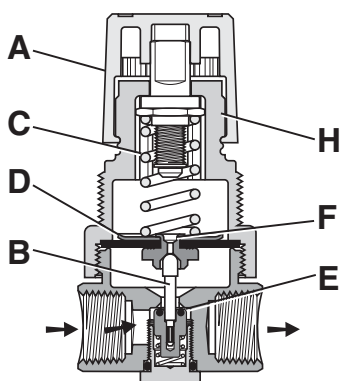

With the adjusting knob (A) turned fully counter-clockwise (no spring load), and pressure supplied to the regulator inlet port, the valve poppet assembly (B) is closed. Turning the adjusting knob clockwise applies a load to control spring (C). This load causes the diaphragm (D) and the valve poppet assembly (B) to move downward allowing flow across the seat area (E) created between the poppet assembly and the seat. Pressure in the downstream line is sensed below the diaphragm (D) and offsets the load of spring (C). As downstream pressure rises, poppet assembly (B) and diaphragm (D) move upward until the area (E) is closed and the load of the spring (C) and pressure under diaphragm (D) are in balance. A reduced outlet pressure has now been obtained, depending on spring load. Creating a demand downstream, such as opening a valve, results in a reduced pressure under the diaphragm (D). The load of control spring (C) now causes the poppet assembly to move downward opening seat area (E) allowing air to flow to meet the downstream demand. The flow of downstream air is metered by the amount of opening (E).

Should downstream pressure exceed the desired regulated pressure, the excess pressure will cause the diaphragm (D) to move upward against control spring (C), open vent hole (F), and vent the excess pressure to atmosphere through the hole in the bonnet (H). (This occurs in the relieving type regulator only.)

Technical Information

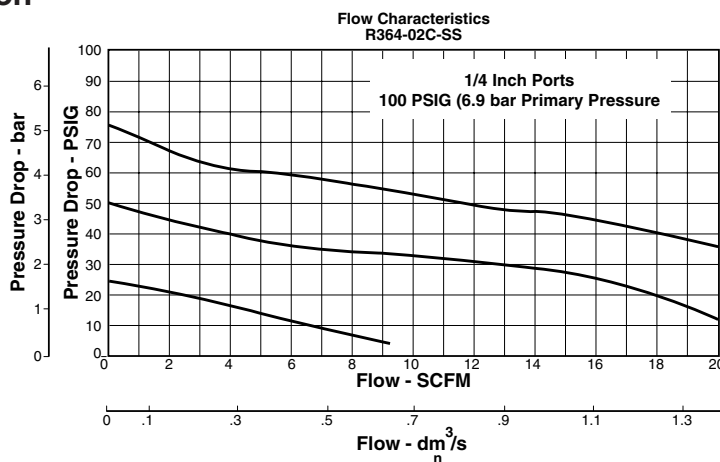

R364 Regulator Kits & Accessories

- Bonnet Kit (Knob Included) CKR364YSS
- Gauge –
 160 PSIG (0 to 1100 kPa) K4515N14160SS
- Panel Mount Nut R05X51-SS
- Pipe Nipple –
 1/4" 316 Stainless Steel 616Y28-SS
- Service Kit –
 Relieving RKR364YSS
 Non-Relieving RKR364KYSS
- Springs –
 0-25 PSIG Range SPR-375-2-SS
 0-60 PSIG Range SPR-376-1-SS
 0-125 PSIG Range SPR-377-1-SS

Specifications

- Gauge Port 1/4 Inch
- Operation Fluorocarbon Diaphragm
- Port Threads 1/4 Inch
- Pressure & Temperature Ratings – 300 PSIG Max (20.7 bar)
 40°F to 150°F (4°C to 66°C)
- Weight 0.5 lb. (0.23 kg)

Materials of Construction

- Adjustment Mechanism / Springs 316 Stainless Steel
- Body 316 Stainless Steel
- Bonnet Acetal
- Bottom Plug 316 Stainless Steel
- Knob Polypropylene
- Poppet 316 Stainless Steel
- Seals Fluorocarbon

R354 Regulator – Miniature

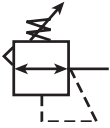

Features

- Stainless Steel Construction Handles Most Corrosive Environments
- Stainless Steel Bonnet and Adjusting Screw
- Large Diaphragm to Valve Area Ratio for Precise Regulation and High Flow Capacity
- Meets NACE Specifications
- High Flow: 1/4" – 12 SCFM[§]
- Relieving

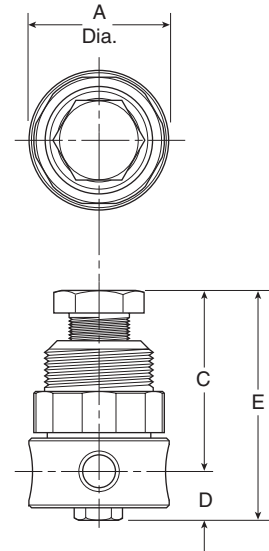

Port Size	NPT	BSPP
1/4"	R354-02CSS	R354G02CSS

R354 Regulator Dimensions		
A	C	D
1.56 (40)	2.00 (51)	0.50 (13)
E		
2.50 (64)		

Standard part numbers shown bold. For other models refer to ordering information below.
[§] SCFM = Standard cubic feet per minute at 100 PSIG inlet, 75 PSIG no flow secondary setting and 125% pressure drop.

WARNING
 Do not connect regulator to bottled gas.
 Do not exceed maximum primary pressure rating.
 Product rupture can cause serious injury.

inches (mm)
 NOTE: 1.25 Dia. (32mm) hole required for panel mounting.

Ordering Information

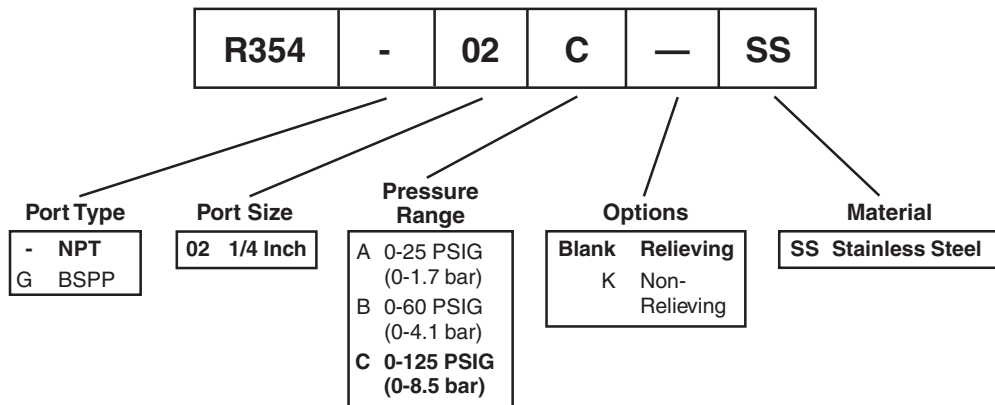

NOTE: BOLD ITEMS ARE STANDARD.

Operation

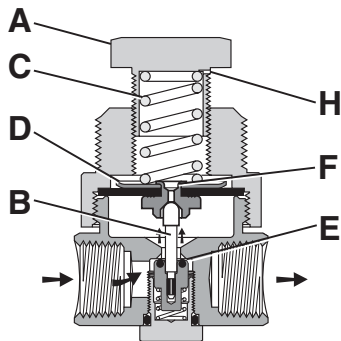

With the adjusting screw (A) turned fully counter-clockwise (no spring load), and pressure supplied to the regulator inlet port, the valve poppet assembly (B) is closed. Turning the adjusting screw clockwise applies a load to control spring (C). This load causes the diaphragm (D) and the valve poppet assembly (B) to move downward allowing flow across the seat area (E) created between the poppet assembly and the seat. Pressure in the downstream line is sensed below the diaphragm (D) and offsets the load of spring (C). As downstream pressure rises, poppet assembly (B) and diaphragm (D) move upward until the area (E) is closed and the load of the spring (C) and pressure under diaphragm (D) are in balance. A reduced outlet pressure has now been obtained, depending on spring load. Creating a demand downstream, such as opening a valve, results in a reduced pressure under the diaphragm (D). The load of control spring (C) now causes the poppet assembly to move downward opening seat area (E) allowing air to flow to meet the downstream demand. The flow of downstream air is metered by the amount of opening (E).

Should downstream pressure exceed the desired regulated pressure, the excess pressure will cause the diaphragm (D) to move upward against control spring (C), open vent hole (F), and vent the excess pressure to atmosphere through the hole in the bonnet (H). (This occurs in the relieving type regulator only.)

Technical Information

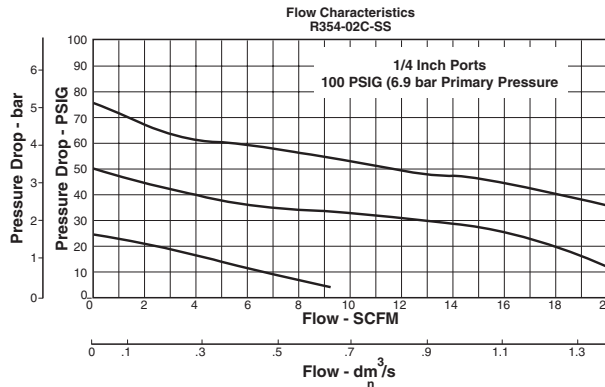

R354 Regulator Kits & Accessories

- Bonnet Kit CKR354YSS
- Gauge –
 160 PSIG (0 to 1100 kPa) K4515N14160SS
- Panel Mount Nut R05X51-SS
- Pipe Nipple –
 1/4" 316 Stainless Steel 616Y28-SS
- Service Kit –
 Relieving RKR364YSS
 Non-Relieving RKR364KYSS
- Springs –
 0-25 PSIG Range SPR-375-2-SS
 0-60 PSIG Range SPR-376-1-SS
 0-125 PSIG Range SPR-377-1-SS

Specifications

- Gauge Port 1/4 Inch
- Operation Fluorocarbon Diaphragm
- Port Threads 1/4 Inch
- Pressure & Temperature Ratings – 300 PSIG Max (20.7 bar)
 40°F to 180°F (4°C to 82°C)
- Weight 1 lb. (0.37 kg)

Materials of Construction

- Adjustment Mechanism / Springs 316 Stainless Steel
- Adjusting Screw 316 Stainless Steel
- Body 316 Stainless Steel
- Bonnet 316 Stainless Steel
- Bottom Plug 316 Stainless Steel
- Poppet 316 Stainless Steel
- Seals Fluorocarbon

R10 Regulator – Standard

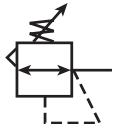

Features

- Stainless Steel Construction Handles Most Corrosive Environments
- Large Diaphragm to Valve Area Ratio for Precise Regulation and High Flow Capacity
- Meets NACE Specifications
- High Flow: 1/2" – 100 SCFM §

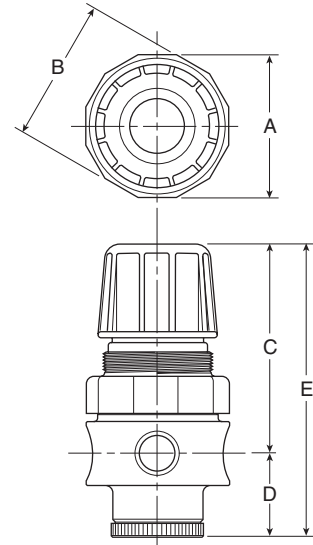

Port Size	NPT	BSPB
1/2"	R10-04CSS	R10G04CSS

R10 Regulator Dimensions		
A 2.34 (60)	B 2.43 (62)	C 3.59 (91)
D 1.38 (35)	E 4.97 (126)	

Standard part numbers shown bold. For other models refer to ordering information below.
 § SCFM = Standard cubic feet per minute at 100 PSIG inlet, 75 PSIG no flow secondary setting and 25% pressure drop.

WARNING
 Do not connect regulator to bottled gas.
 Do not exceed maximum primary pressure rating.
 Product rupture can cause serious injury.

inches
 (mm)
 NOTE: 1.75 Dia. (44mm) hole required for panel mounting.

Ordering Information

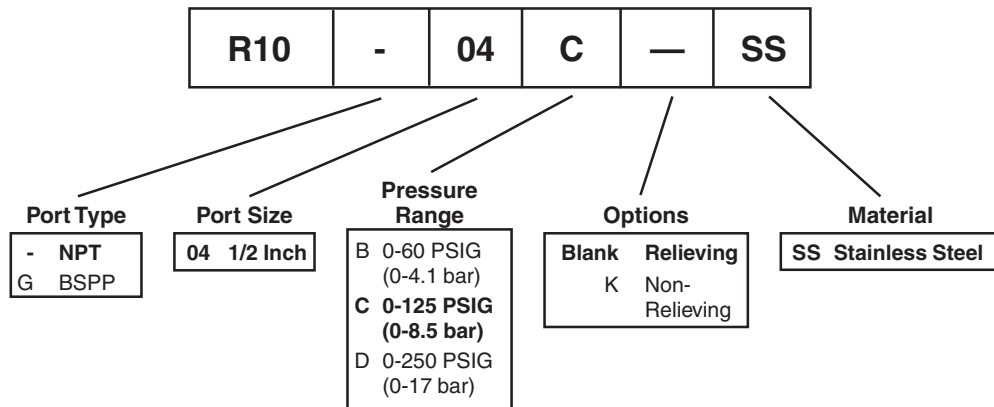

NOTE: BOLD ITEMS ARE STANDARD.

Operation

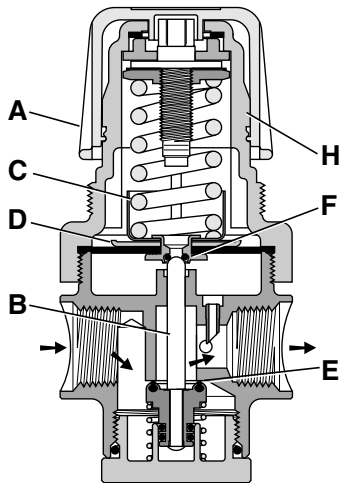

With the adjusting knob (A) turned fully counter-clockwise (no spring load), and pressure supplied to the regulator inlet port, the valve poppet assembly (B) is closed. Turning the adjusting knob clockwise applies a load to control spring (C). This load causes the diaphragm (D) and the valve poppet assembly (B) to move downward allowing flow across the seat area (E) created between the poppet assembly and the seat. Pressure in the downstream line is sensed below the diaphragm (D) and offsets the load of spring (C). As downstream pressure rises, poppet assembly (B) and diaphragm (D) move upward until the area (E) is closed and the load of the spring (C) and pressure under diaphragm (D) are in balance. A reduced outlet pressure has now been obtained, depending on spring load. Creating a demand downstream, such as opening a valve, results in a reduced pressure under the diaphragm (D). The load of control spring (C) now causes the poppet assembly to move downward opening seat area (E) allowing air to flow to meet the downstream demand. The flow of downstream air is metered by the amount of opening (E).

Should downstream pressure exceed the desired regulated pressure, the excess pressure will cause the diaphragm (D) to move upward against control spring (C), open vent hole (F), and vent the excess pressure to atmosphere through the hole in the bonnet (H). (This occurs in the relieving type regulator only.)

Technical Information

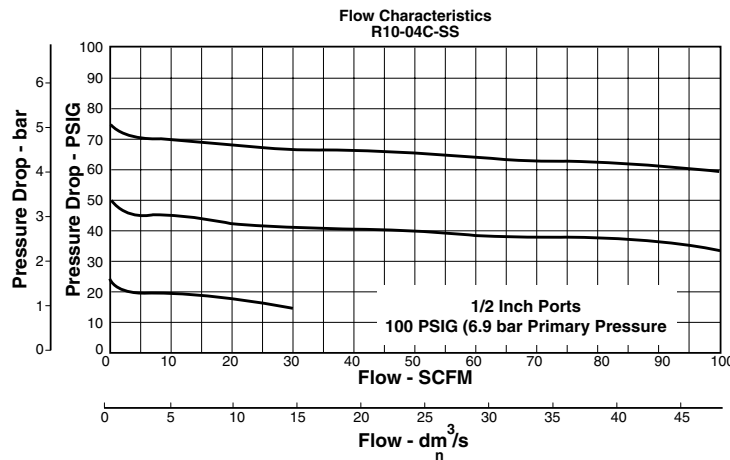

R10 Regulator Kits & Accessories

- Bonnet Kit (Knob Included) CKR10YSS
- Gauge –
 160 PSIG (0 to 1100 kPa) K4520N14160SS
- Panel Mount Nut R10X51-SS
- Pipe Nipple –
 1/2" 316 Stainless Steel 616A28-SS
- Service Kit –
 Relieving RKR10YSS
 Non-Relieving RKR10KYSS
- Springs –
 0-60 PSIG Range SPR-388-1-SS
 0-125 PSIG Range SPR-389-1-SS
 0-250 PSIG Range SPR-390-1-SS

Specifications

- Gauge Port 1/4 Inch
- Operation Fluorocarbon Diaphragm
- Port Threads 1/2 Inch
- Pressure & Temperature Ratings – 300 PSIG Max (20.7 bar)
 40°F to 150°F (4°C to 66°C)
- Weight 1.79 lb. (0.81 kg)

Materials of Construction

- Adjustment Mechanism / Springs 316 Stainless Steel
- Body 316 Stainless Steel
- Bonnet / Knob Acetal
- Bottom Plug 316 Stainless Steel
- Poppet 316 Stainless Steel
- Seals Fluorocarbon

B548 Filter / Regulator – Miniature

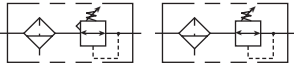

Features

- Stainless Steel Construction Handles Most Corrosive Environments
- Large Diaphragm to Valve Area Ratio for Precise Regulation and High Flow Capacity
- Meets NACE Specifications
- High Flow: 1/4" – 12 SCFM[§]

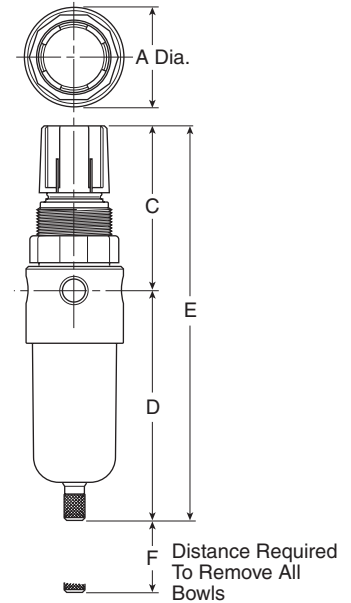

Port Size	NPT	BSPP
1/4"	B548-02DHCSS	B548G02DHCSS

B548 Piggyback Dimensions		
A	C	D
1.56 (40)	2.63 (67)	3.63 (92)
E	F	
6.25 (159)	1.58 (40)	

Standard part numbers shown bold. For other models refer to ordering information below.
[§] SCFM = Standard cubic feet per minute at 100 PSIG inlet, 75 PSIG no flow secondary setting and 25% pressure drop.

⚠ WARNING
 Do not connect regulator to bottled gas.
 Do not exceed maximum primary pressure rating.
 Product rupture can cause serious injury.

inches
 (mm)
 NOTE: 1.25 Dia. (32mm) hole required for panel mounting.

Ordering Information

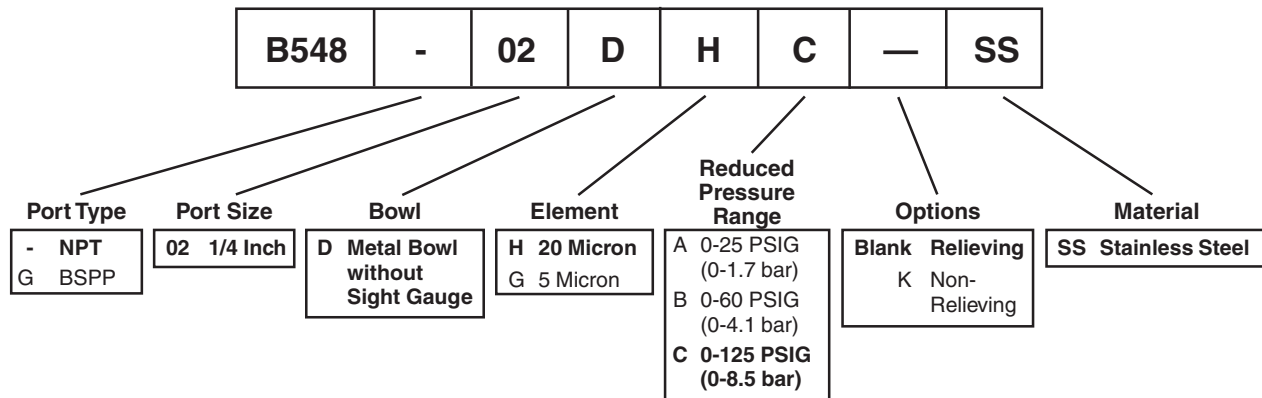

NOTE: BOLD ITEMS ARE STANDARD.

Operation

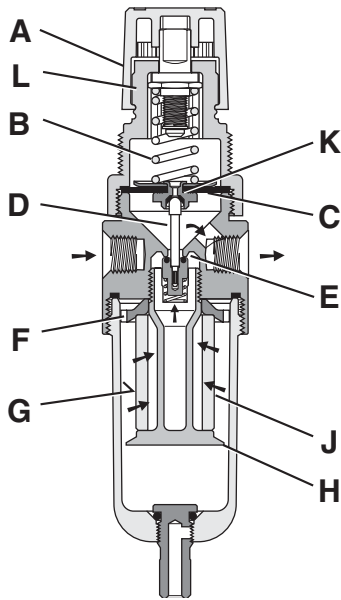

Turning the adjusting knob clockwise applies a load to control spring (B) which forces diaphragm (C) and valve poppet assembly (D) to move downward allowing filtered air to flow through the seat area (E) created between the poppet assembly and the seat. “**First stage filtration**”. Air pressure supplied to the inlet port is directed through deflector plate (F) causing a swirling centrifugal action forcing liquids and coarse particles to the inner bowl wall (G) and down below the lower baffle (H) to the quiet zone. After liquids and large particles are removed in the first stage of filtration “**second stage filtration**” occurs as air flows through element (J) where smaller particles are filtered out and retained. The air flow now passes through seat area (E) to the outlet port of the unit. Pressure in the downstream line is sensed below the diaphragm (C) and offsets the load of spring (B). When downstream pressure reaches the set-point, poppet valve assembly (D) and diaphragm (C) move upward closing seat area (E). Should downstream pressure exceed the desired regulated pressure, the excess pressure will cause the diaphragm (C) to move upward opening vent hole (K) venting the excess pressure to atmosphere through the hole in the bonnet (L). (This occurs in the standard relieving type filter/regulators only.)

Technical Information

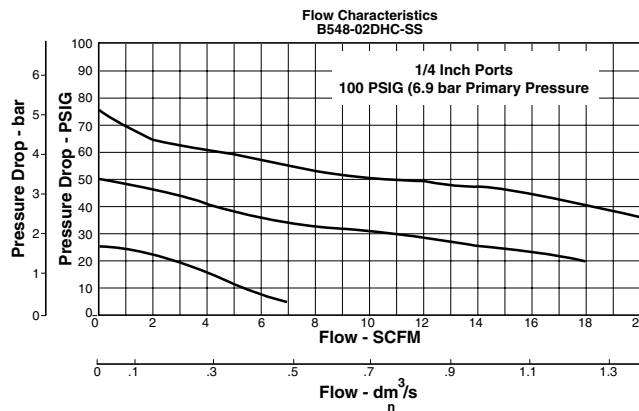

B548 Regulator Kits & Accessories

- Bonnet Kit (Knob Included) CKR364YSS
- Filter Element Kits –
 - Particulate (5 Micron) EK504VY
 - Particulate (20 Micron) EK504Y
- Gauge –
 - 160 PSIG (0 to 1100 kPa) K4515N14160SS
- Manual Twist Drain SA600Y71SS
- Panel Mount Nut R05X51-SS
- Pipe Nipple –
 - 1/4" 316 Stainless Steel 616Y28-SS
- Service Kit –
 - Relieving RK549YSS
 - Non-Relieving RK548YSS
- Springs –
 - 0-25 PSIG Range SPR-375-2-SS
 - 0-60 PSIG Range SPR-376-1-SS
 - 0-125 PSIG Range SPR-377-1-SS

Specifications

- Bowl Capacity 1.0 Ounces
- Filter Rating 20 Micron
- Gauge Port 1/4 Inch
- Operation Fluorocarbon Diaphragm
- Port Threads 1/4 Inch
- Pressure & Temperature Ratings – 300 PSIG Max (20.7 bar)
 40°F to 150°F (4°C to 66°C)
- Sump Capacity 0.4 Ounce
- Weight 0.6 lb. (0.27 kg)

Materials of Construction

- Adjustment Mechanism / Springs 316 Stainless Steel
- Body 316 Stainless Steel
- Bonnet Acetal
- Bottom Plug 316 Stainless Steel
- Knob Polypropylene
- Poppet 316 Stainless Steel
- Seals Fluorocarbon

B558 Filter / Regulator – Miniature

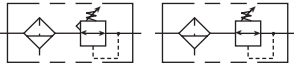

Features

- Stainless Steel Construction Handles Most Corrosive Environments
- Stainless Steel Bonnet and Adjusting Screw
- Large Diaphragm to Valve Area Ratio for Precise Regulation and High Flow Capacity
- Meets NACE Specifications
- High Flow: 1/4" – 12 SCFM[§]

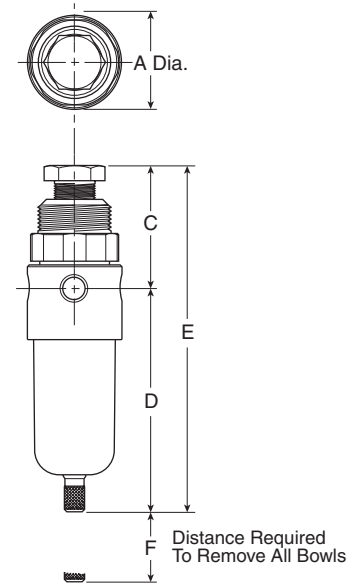

Port Size	NPT	BSPP
1/4"	B558-02DHCSS	B558G02DHCSS

B558 Piggyback Dimensions		
A 1.53 39 mm	C 2.17 55 mm	D 3.63 92 mm
E 5.80 147 mm	F 1.58 40 mm	

Standard part numbers shown bold. For other models refer to ordering information below.

[§] SCFM = Standard cubic feet per minute at 100 PSIG inlet, 75 PSIG no flow secondary setting and 25% pressure drop.

⚠ WARNING

**Do not connect regulator to bottled gas.
 Do not exceed maximum primary pressure rating.
 Product rupture can cause serious injury.**

inches
(mm)

NOTE: 1.25 Dia. (32mm) hole required for panel mounting.

Ordering Information

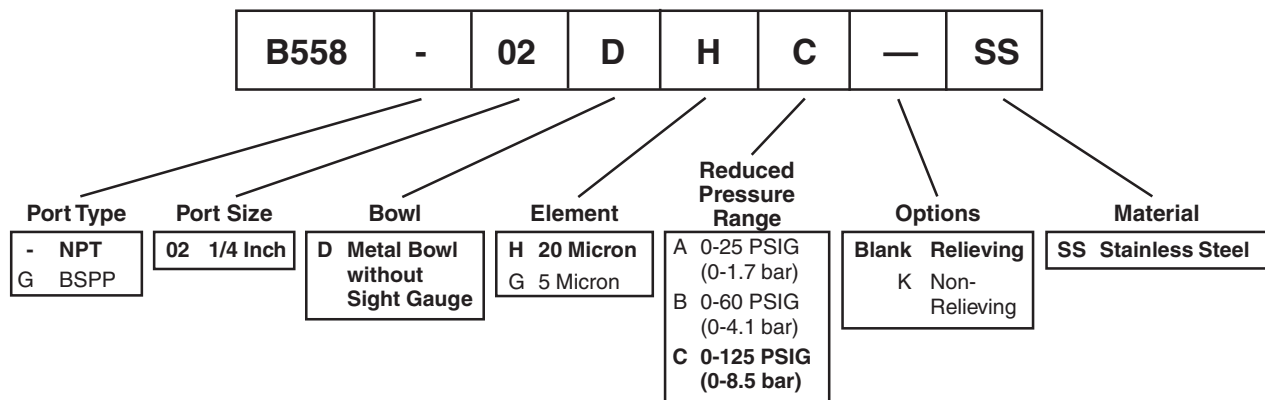

NOTE: BOLD ITEMS ARE STANDARD.

Operation

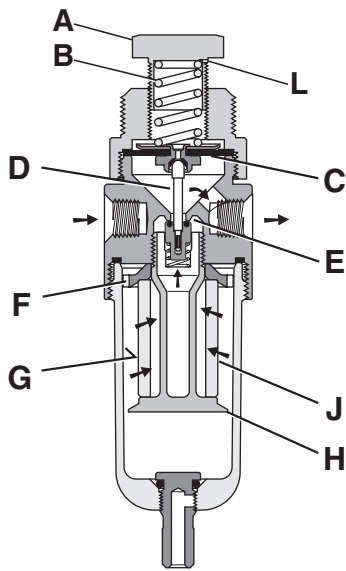

Turning the adjusting knob clockwise applies a load to control spring (B) which forces diaphragm (C) and valve poppet assembly (D) to move downward allowing filtered air to flow through the seat area (E) created between the poppet assembly and the seat. “**First stage filtration**”. Air pressure supplied to the inlet port is directed through deflector plate (F) causing a swirling centrifugal action forcing liquids and coarse particles to the inner bowl wall (G) and down below the lower baffle (H) to the quiet zone. After liquids and large particles are removed in the first stage of filtration “**second stage filtration**” occurs as air flows through element (J) where smaller particles are filtered out and retained. The air flow now passes through seat area (E) to the outlet port of the unit. Pressure in the downstream line is sensed below the diaphragm (C) and offsets the load of spring (B). When downstream pressure reaches the set-point, poppet valve assembly (D) and diaphragm (C) move upward closing seat area (E). Should downstream pressure exceed the desired regulated pressure, the excess pressure will cause the diaphragm (C) to move upward opening vent hole (K) venting the excess pressure to atmosphere through the hole in the bonnet (L). (This occurs in the standard relieving type filter/regulators only.)

Technical Information

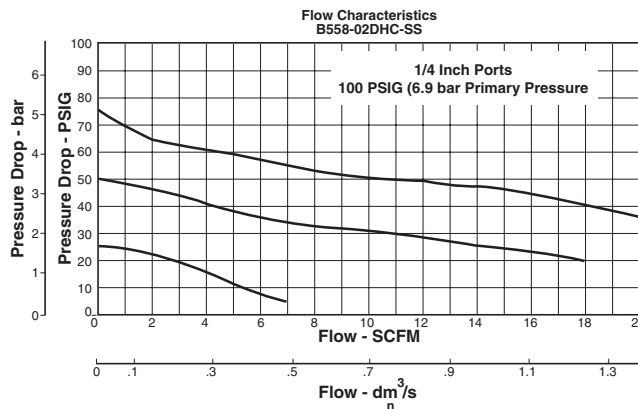

B558 Regulator Kits & Accessories

- Bonnet Kit (Knob Included) CKR354YSS
- Filter Element Kits –
 - Particulate (5 Micron) EK504VY
 - Particulate (20 Micron) EK504Y
- Gauge –
 - 160 PSIG (0 to 1100 kPa) K4515N14160SS
- Manual Twist Drain SA600Y71SS
- Panel Mount Nut R05X51-SS
- Pipe Nipple –
 - 1/4" 316 Stainless Steel 616Y28-SS
- Service Kit –
 - Relieving RK549YSS
 - Non-Relieving RK548YSS
- Springs –
 - 0-25 PSIG Range SPR-375-2-SS
 - 0-60 PSIG Range SPR-376-1-SS
 - 0-125 PSIG Range SPR-377-1-SS

Specifications

- Bowl Capacity 1.0 Ounces
- Filter Rating 20 Micron
- Gauge Port 1/4 Inch
- Operation Fluorocarbon Diaphragm
- Port Threads 1/4 Inch
- Pressure & Temperature Ratings – 300 PSIG Max (20.7 bar)
 40°F to 180°F (4°C to 82°C)
- Sump Capacity 0.4 Ounce
- Weight 0.6 lb. (0.27 kg)

Materials of Construction

- Adjustment Mechanism / Springs 316 Stainless Steel
- Body 316 Stainless Steel
- Bonnet 316 Stainless Steel
- Bottom Plug 316 Stainless Steel
- Knob 316 Stainless Steel
- Poppet 316 Stainless Steel
- Seals Fluorocarbon

B11 Filter / Regulator – Standard

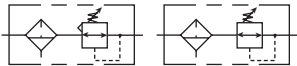

Features

- Stainless Steel Construction Handles Most Corrosive Environments
- Large Diaphragm to Valve Area Ratio for Precise Regulation and High Flow Capacity
- Meets NACE Specifications
- High Flow: 1/2" – 72 SCFM[§]

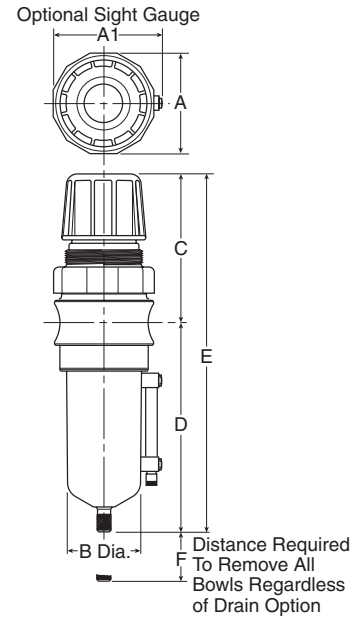

Port Size	NPT	BSPB
1/2"	B11-04DJCSS	B11G04DJCSS

B11 Piggyback Dimensions		
A	A1	B
2.34 (60)	2.50 (64)	1.75 (44)
C	D	E
3.59 (91)	5.00 (127)	8.59 (218)
F		
2.12 (54)		

Standard part numbers shown bold. For other models refer to ordering information below.
[§] SCFM = Standard cubic feet per minute at 100 PSIG inlet, 90 PSIG no flow secondary setting and 10 PSIG pressure drop.

WARNING
 Do not connect regulator to bottled gas.
 Do not exceed maximum primary pressure rating.
 Product rupture can cause serious injury.

inches
 (mm)
 NOTE: 1.75 Dia. (44mm) hole required for panel mounting.

Ordering Information

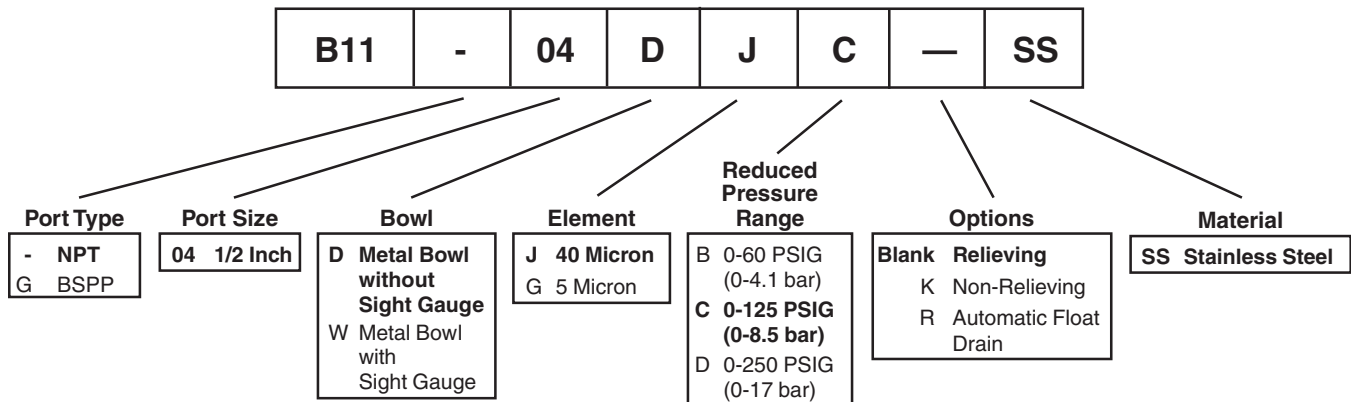

NOTE: BOLD ITEMS ARE STANDARD.

Operation

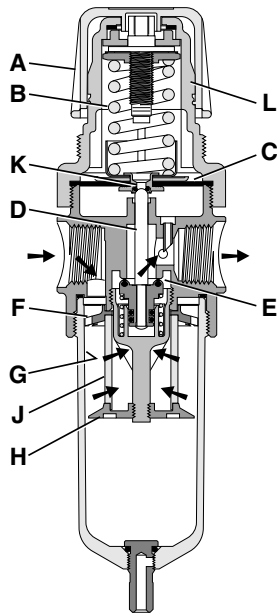

Turning the adjusting knob clockwise applies a load to control spring (B) which forces diaphragm (C) and valve poppet assembly (D) to move downward allowing filtered air to flow through the seat area (E) created between the poppet assembly and the seat. “**First stage filtration**”.

Air pressure supplied to the inlet port is directed through deflector plate (F) causing a swirling centrifugal action forcing liquids and coarse particles to the inner bowl wall (G) and down below the lower baffle (H) to the quiet zone. After liquids and large particles are removed in the first stage of filtration “**second stage filtration**” occurs as air flows through element (J) where smaller particles are filtered out and retained. The air flow now passes through seat area (E) to the outlet port of the unit. Pressure in the downstream line is sensed below the diaphragm (C) and offsets the load of spring (B). When downstream pressure reaches the set-point, poppet valve assembly (D) and diaphragm (C) move upward closing seat area (E). Should downstream pressure exceed the desired regulated pressure, the excess pressure will cause the diaphragm (C) to move upward opening vent hole (K) venting the excess pressure to atmosphere through the hole in the bonnet (L). (This occurs in the standard relieving type filter/regulators only.)

Technical Information

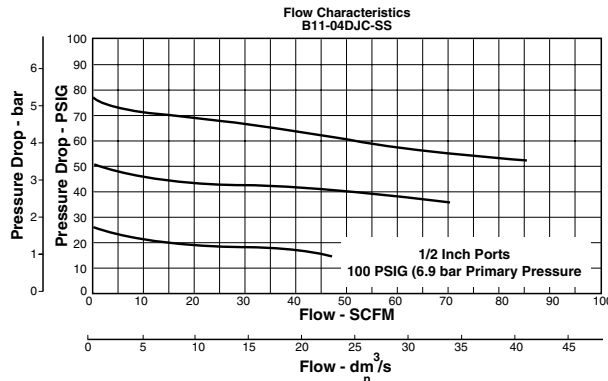

B11 Regulator Kits & Accessories

- Bonnet Kit (Knob Included) CKR10YSS
- Drain Kit –
 - Automatic Float Drain SA602MDSS
 - Manual Twist Drain SA600Y7-1SS
- Filter Element Kits –
 - Particulate (40 Micron) EKF10Y
 - Particulate (5 Micron) EKF10VY
- Gauge –
 - 160 PSIG (0 to 1100 kPa) K4520N14160SS
- Panel Mount Nut R10X51-SS
- Pipe Nipple –
 - 1/2" 316 Stainless Steel 616A28-SS
- Service Kit –
 - Relieving RKR10YSS
 - Non-Relieving RKR10KYSS
- Springs –
 - 0-60 PSIG Range SPR-388-1-SS
 - 0-125 PSIG Range SPR-389-1-SS
 - 0-250 PSIG Range SPR-390-1-SS

Specifications

- Bowl Capacity 4.0 Ounces
- Filter Rating 40 Micron
- Gauge Port 1/4 Inch
- Operation Fluorocarbon Diaphragm
- Port Threads 1/2 Inch
- Pressure & Temperature Ratings –
 - Metal Bowl (D) 300 PSIG Max (20.7 bar)
40°F to 150°F (4°C to 66°C) Auto Drain Ratings
 - Metal Bowl (W) 0 to 250 PSIG (0 to 17.2 bar)
40°F to 150°F (4°C to 66°C)
 - Automatic Float Drain 15 to 175 PSIG (1 to 12 bar)
40°F to 125°F (4°C to 52°C)
- Sump Capacity 1.7 Ounce
- Weight 2.42 lb. (1.09 kg)

Materials of Construction

- Adjustment Mechanism / Springs 316 Stainless Steel
- Body 316 Stainless Steel
- Bonnet / Knob Acetal
- Bottom Plug 316 Stainless Steel
- Poppet 316 Stainless Steel
- Seals Fluorocarbon
- Sight Gauge Isoplast

L10 Lubricator – Standard

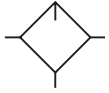

Features

- Stainless Steel Construction Handles Most Corrosive Environments
- Meets NACE Specifications
- High Flow: 1/2" – 100 SCFM §

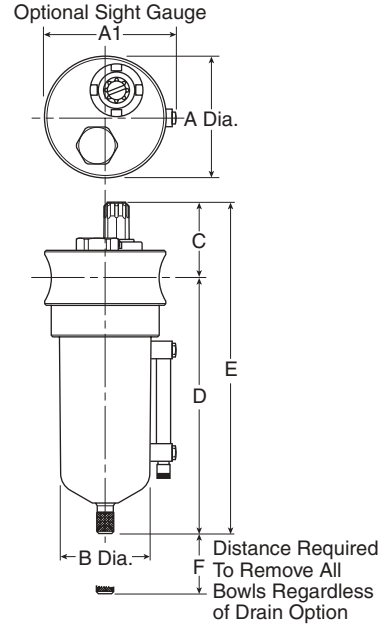

Port Size	NPT	BSPP
1/2"	L10-04DSS	L10G04DSS

L10 Lubricator Dimensions		
A	A ₁	B
2.38 (60)	2.50 (64)	1.75 (44)
C	D	E
1.81 (46)	5.00 (127)	6.81 (173)
F		
3.50 (89)		

Standard part numbers shown bold. For other models refer to ordering information below.
 § SCFM = Standard cubic feet per minute at 90 PSIG inlet and 5 PSIG pressure drop.

inches
(mm)

Ordering Information

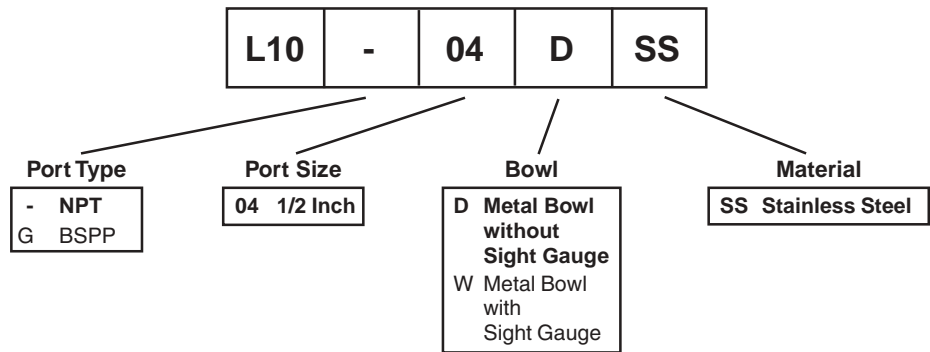

NOTE: BOLD ITEMS ARE STANDARD.

Operation

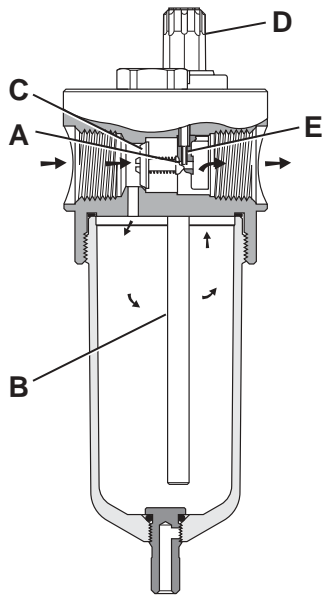

Air flowing through the unit goes through two paths. At low flow rates the majority of the air flows through the Venturi section (A). The rest of the air opens the check valve (C). The velocity of the air flowing through the Venturi section (A) creates a pressure drop. This lower pressure allows the oil to be forced from the reservoir through the pickup tube (B) and travels up to the metering screw (D). The rate of oil delivery is then controlled by adjusting the metering screw (D). Oil flows past the metering screw (D) and forms a drop in the nozzle tube (E). As the oil drops through the dome (F) and back into the Venturi section (A), it is broken up into fine particles. It is then mixed with the air flowing past the check valve (C) and is carried downstream. As the air flow increases the check valve (C) will open more fully. This additional flow will assure that the oil delivery rate will increase linearly with the increase of air flow.

Technical Information

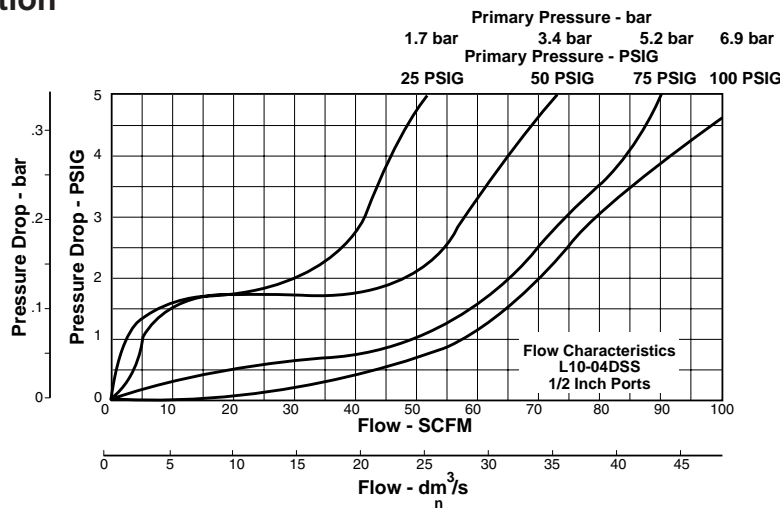

L10 Filter Kits & Accessories

- Drain Kit –
 - Manual Twist Drain SA600Y7-1SS
- Pipe Nipple –
 - 1/2" 316 Stainless Steel 616A28-SS
- Sight Dome Kit RKL10SS

Specifications

- Bowl Capacity 4.0 Ounces
- Port Threads 1/2 Inch

Pressure & Temperature Ratings –

- Metal Bowl (D) 300 PSIG Max (20.7 bar)
40°F to 150°F (4°C to 66°C) Auto Drain Ratings
- Metal Bowl (W) 0 to 250 PSIG (0 to 17.2 bar)
40°F to 150°F (4°C to 66°C)

Weight 1.9 lb. (0.85 kg)

Materials of Construction

- Body 316 Stainless Steel
- Bowl 316 Stainless Steel
- Dip Tube 316 Stainless Steel
- Drain 316 Stainless Steel
- Fill Plug 316 Stainless Steel
- Seals Fluorocarbon
- Sight Dome Nylon
- Sight Gauge Isoplast

Offer of Sale

The items described in this document and other documents or descriptions provided by The Company, its subsidiaries and its authorized distributors, are hereby offered for sale at prices to be established by The Company, its subsidiaries and its authorized distributors. This offer and its acceptance by any customer ("Buyer") shall be governed by all of the following Terms and Conditions. Buyer's order for any such item, when communicated to The Company, its subsidiaries or an authorized distributor ("Seller") verbally or in writing, shall constitute acceptance of this offer.

1. Terms and Conditions of Sale: All descriptions, quotations, proposals, offers, acknowledgments, acceptances and sales of Seller's products are subject to and shall be governed exclusively by the terms and conditions stated herein. Buyer's acceptance of any offer to sell is limited to these terms and conditions. Any terms or conditions in addition to, or inconsistent with those stated herein, proposed by Buyer in any acceptance of an offer by Seller, are hereby objected to. No such additional, different or inconsistent terms and conditions shall become part of the contract between Buyer and Seller unless expressly accepted in writing by Seller. Seller's acceptance of any offer to purchase by Buyer is expressly conditional upon Buyer's assent to all the terms and conditions stated herein, including any terms in addition to, or inconsistent with those contained in Buyer's offer. Acceptance of Seller's products shall in all events constitute such assent.

2. Payment: Payment shall be made by Buyer net 30 days from the date of delivery of the items purchased hereunder. Amounts not timely paid shall bear interest at the maximum rate permitted by law for each month or portion thereof that the Buyer is late in making payment. Any claims by Buyer for omissions or shortages in a shipment shall be waived unless Seller receives notice thereof within 30 days after Buyer's receipt of the shipment.

3. Delivery: Unless otherwise provided on the face hereof, delivery shall be made F.O.B. Seller's plant. Regardless of the method of delivery, however, risk of loss shall pass to Buyer upon Seller's delivery to a carrier. Any delivery dates shown are approximate only and Seller shall have no liability for any delays in delivery.

4. Warranty: Seller warrants that the items sold hereunder shall be free from defects in material or workmanship for a period of 18 months from date of shipment from Parker Hannifin Corporation. THIS WARRANTY COMPRISES THE SOLE AND ENTIRE WARRANTY PERTAINING TO ITEMS PROVIDED HEREUNDER. SELLER MAKES NO OTHER WARRANTY, GUARANTEE, OR REPRESENTATION OF ANY KIND WHATSOEVER. ALL OTHER WARRANTIES, INCLUDING BUT NOT LIMITED TO, MERCHANTABILITY AND FITNESS FOR PURPOSE, WHETHER EXPRESS, IMPLIED, OR ARISING BY OPERATION OF LAW, TRADE USAGE, OR COURSE OF DEALING ARE HEREBY DISCLAIMED.

NOTWITHSTANDING THE FOREGOING, THERE ARE NO WARRANTIES WHATSOEVER ON ITEMS BUILT OR ACQUIRED WHOLLY OR PARTIALLY, TO BUYER'S DESIGN OR SPECIFICATIONS.

5. Limitation of Remedy: SELLER'S LIABILITY ARISING FROM OR IN ANY WAY CONNECTED WITH THE ITEMS SOLD OR THIS CONTRACT SHALL BE LIMITED EXCLUSIVELY TO REPAIR OR REPLACEMENT OF THE ITEMS SOLD OR REFUND OF THE PURCHASE PRICE PAID BY BUYER, AT SELLER'S SOLE OPTION. IN NO EVENT SHALL SELLER BE LIABLE FOR ANY INCIDENTAL, CONSEQUENTIAL OR SPECIAL DAMAGES OF ANY KIND OR NATURE WHATSOEVER, INCLUDING BUT NOT LIMITED TO LOST PROFITS ARISING FROM OR IN ANY WAY CONNECTED WITH THIS AGREEMENT OR ITEMS SOLD HEREUNDER, WHETHER ALLEGED TO ARISE FROM BREACH OF CONTRACT, EXPRESS OR IMPLIED WARRANTY, OR IN TORT, INCLUDING WITHOUT LIMITATION, NEGLIGENCE, FAILURE TO WARN OR STRICT LIABILITY.

6. Changes, Reschedules and Cancellations: Buyer may request to modify the designs or specifications for the items sold hereunder as well as the quantities and delivery dates thereof, or may request to cancel all or part of this order, however, no such requested modification or cancellation shall become part of the contract between Buyer and Seller unless accepted by Seller in a written amendment to this Agreement. Acceptance of any such requested modification or cancellation shall be at Seller's discretion, and shall be upon such terms and conditions as Seller may require.

7. Special Tooling: A tooling charge may be imposed for any special tooling, including without limitations, dies, fixtures, molds and patterns, acquired to manufacture items sold pursuant to this contract. Such special tooling shall be and remain Seller's property notwithstanding payment of any charges by Buyer. In no event will Buyer acquire any interest in apparatus belonging to Seller which is utilized in the manufacture of the items sold hereunder, even if such apparatus has been specially converted or adapted for such manufacture and notwithstanding any charges paid

by Buyer. Unless otherwise agreed, Seller shall have the right to alter, discard or otherwise dispose of any special tooling or other property in its sole discretion at any time.

8. Buyer's Property: Any designs, tools, patterns, materials, drawings, confidential information or equipment furnished by Buyer, or any other items which become Buyer's property, may be considered obsolete and may be destroyed by Seller after two (2) consecutive years have elapsed without Buyer placing an order for the items which are manufactured using such property. Seller shall not be responsible for any loss or damage to such property while it is in Seller's possession or control.

9. Taxes: Unless otherwise indicated on the face hereof, all prices and charges are exclusive of excise, sales, use, property, occupational or like taxes which may be imposed by any taxing authority upon the manufacture, sale or delivery of the items sold hereunder. If any such taxes must be paid by Seller or if Seller is liable for the collection of such tax, the amount thereof shall be in addition to the amounts for the items sold. Buyer agrees to pay all such taxes or to reimburse Seller therefore upon receipt of its invoice. If Buyer claims exemption from any sales, use or other tax imposed by any taxing authority, Buyer shall save Seller harmless from and against any such tax, together with any interest or penalties thereon which may be assessed if the items are held to be taxable.

10. Indemnity For Infringement of Intellectual Property Rights: Seller shall have no liability for infringement of any patents, trademarks, copyrights, trade dress, trade secrets or similar rights except as provided in this Part 10. Seller will defend and indemnify Buyer against allegations of infringement of U.S. patents, U.S. trademarks, copyrights, trade dress and trade secrets (hereinafter "Intellectual Property Rights"). Seller will defend at its expense and will pay the cost of any settlement or damages awarded in an action brought against Buyer based on an allegation that an item sold pursuant to this contract infringes the Intellectual Property Rights of a third party. Seller's obligation to defend and indemnify Buyer is contingent on Buyer notifying Seller within ten (10) days after Buyer becomes aware of such allegations of infringement, and Seller having sole control over the defense of any allegations or actions including all negotiations for settlement or compromise. If an item sold hereunder is subject to a claim that it infringes the Intellectual Property Rights of a third party, Seller may, at its sole expense and option, procure for Buyer the right to continue using said item, replace or modify said item so as to make it noninfringing, or offer to accept return of said item and return the purchase price less a reasonable allowance for depreciation. Notwithstanding the foregoing, Seller shall have no liability for claims of infringement based on information provided by Buyer, or directed to items delivered hereunder for which the designs are specified in whole or part by Buyer, or infringements resulting from the modification, combination or use in a system of any item sold hereunder. The foregoing provisions of this Part 10 shall constitute Seller's sole and exclusive liability and Buyer's sole and exclusive remedy for infringement of Intellectual Property Rights.

If a claim is based on information provided by Buyer or if the design for an item delivered hereunder is specified in whole or in part by Buyer, Buyer shall defend and indemnify Seller for all costs, expenses or judgements resulting from any claim that such item infringes any patent, trademark, copyright, trade dress, trade secret or any similar right.

11. Force Majeure: Seller does not assume the risk of and shall not be liable for delay or failure to perform any of Seller's obligations by reason of circumstances beyond the reasonable control of Seller (hereinafter "Events of Force Majeure"). Events of Force Majeure shall include without limitation, accidents, acts of God, strikes or labor disputes, acts, laws, rules or regulations of any government or government agency, fires, floods, delays or failures in delivery of carriers or suppliers, shortages of materials and any other cause beyond Seller's control.

12. Entire Agreement/Governing Law: The terms and conditions set forth herein, together with any amendments, modifications and any different terms or conditions expressly accepted by Seller in writing, shall constitute the entire Agreement concerning the items sold, and there are no oral or other representations or agreements which pertain thereto. This Agreement shall be governed in all respects by the law of the State of Ohio. No actions arising out of sale of the items sold hereunder or this Agreement may be brought by either party more than two (2) years after the cause of action accrues.



Parker Hannifin Corporation
Pneumatic Division
8676 E. M89
P.O. Box 901
Richland, MI 49083 USA

Customer/Technical Service

Tel: (269) 629-5575
Fax: (269) 629-5385
Website: www.wattsfluidair.com
E-mail: wattsfluidair@parker.com