

# Miniature FRL Series

Catalog 0714W-2



---

 **WARNING**

FAILURE OR IMPROPER SELECTION OR IMPROPER USE OF THE PRODUCTS AND/OR SYSTEMS DESCRIBED HEREIN OR RELATED ITEMS CAN CAUSE DEATH, PERSONAL INJURY AND PROPERTY DAMAGE.

This document and other information from Parker Hannifin Corporation, its subsidiaries and authorized distributors provide product and/or system options for further investigation by users having technical expertise. It is important that you analyze all aspects of your application including consequences of any failure, and review the information concerning the product or system in the current product catalog. Due to the variety of operating conditions and applications for these products or systems, the user, through its own analysis and testing, is solely responsible for making the final selection of the products and systems and assuring that all performance, safety and warning requirements of the application are met.

The products described herein, including without limitation, product features, specifications, designs, availability and pricing, are subject to change by Parker Hannifin Corporation and its subsidiaries at any time without notice.

**Offer of Sale**

The items described in this document are hereby offered for sale by Parker Hannifin Corporation, its subsidiaries or its authorized distributors. This offer and its acceptance are governed by the provisions stated on the separate page of this document entitled "Offer of Sale".

© Copyright 2005 Parker Hannifin Corporation. All Rights Reserved.

**Table of Contents**

**Air Line Filters**  
     Miniature 14F ..... 2-3  
     Miniature F504 ..... 4-5

**Air Line Coalescing Filters**  
     Miniature 10F ..... 6-7  
     Miniature F501, F507 ..... 8-9

**Air Line Regulators**  
     Miniature 14R ..... 10-11  
     Miniature P3A-R ..... 12-13  
     Miniature P3A-W ..... 14-15  
     Miniature R45 ..... 16-17  
     Miniature R364, R374 ..... 18-19

**Air Line Filter / Regulators**  
     Miniature 14E ..... 20-21  
     Miniature B548 ..... 22-23

**Air Line Lubricators**  
     Miniature 04L ..... 24-25  
     Miniature L508 ..... 26-27

**Air Line Combinations**  
     Miniature 2-Unit 14G ..... 28-29  
     Miniature 3-Unit 14A ..... 28-29  
     Miniature 2-Unit C528 ..... 30-31  
     Miniature 3-Unit 528 ..... 30-31

**Mounting Bracket Kits** ..... 29 & 31

**Relief Valves - Diaphragm Type**  
     130 and 134 Series ..... 32

**Safety Guide** ..... 34-35

**Offer of Sale** ..... 36

 **CAUTION:**  
 Polycarbonate bowls, being transparent and tough, are ideal for use with Filters and Lubricators. They are suitable for use in normal industrial environments, but should not be located in areas where they could be subjected to direct sunlight, an impact blow, nor temperatures outside of the rated range. As with most plastics, some chemicals can cause damage. Polycarbonate bowls should not be exposed to chlorinated hydro-carbons, ketones, esters and certain alcohols. They should not be used in air systems where compressors are lubricated with fire-resistant fluids such as phosphate ester and di-ester types.

Metal bowls are recommended where ambient and/or media conditions are not compatible with polycarbonate bowls. Metal bowls resist the action of most such solvents, but should not be used where strong acids or bases are present or in salt laden atmospheres. Consult the factory for specific recommendations where these conditions exist.

**TO CLEAN POLYCARBONATE BOWLS USE MILD SOAP AND WATER ONLY! DO NOT** use cleansing agents such as acetone, benzene, carbon tetrachloride, gasoline, toluene, etc., which are damaging to this plastic.

**Metal bowl guards are recommended for all applications.**

 **CAUTION:**  
**REGULATOR PRESSURE ADJUSTMENT** – The working range of knob adjustment is designed to permit outlet pressures within their full range. Pressure adjustment beyond this range is also possible because the knob is not a limiting device. This is a common characteristic of most industrial regulators, and limiting devices may be obtained only by special design.

**14F Filters – Miniature**

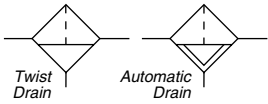

**Features**

- Excellent water removal efficiency.
- Unique deflector plate that creates swirling of the air stream ensuring maximum water and dirt separation.
- Easily disassembled for servicing without the use of tools.
- 5 micron element standard.
- Interchangeable Twist and Automatic Pulse Drains.
- High Flow: 1/8" – 22 SCFM<sup>§</sup>  
 1/4" – 24 SCFM<sup>§</sup>

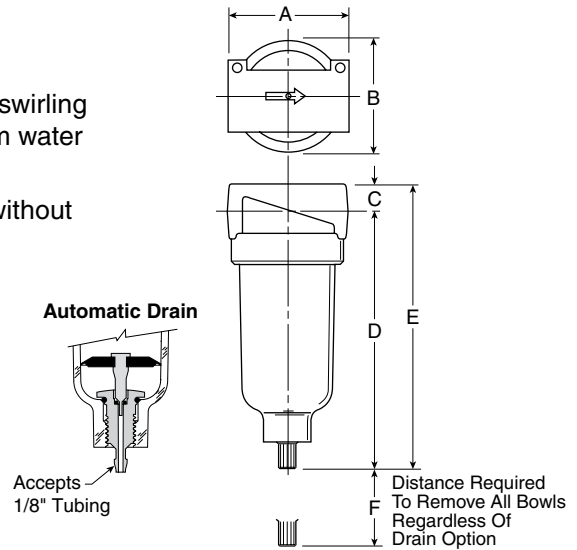

Port Size	NPT	
	Twist Drain	Automatic Pulse Drain
Poly Bowl †		
1/8"	<b>14F01B*</b>	<b>14F05B*</b>
1/4"	<b>14F11B*</b>	<b>14F15B*</b>
Metal Bowl without Sight Gauge		
1/8"	<b>14F03B*</b>	<b>14F07B*</b>
1/4"	<b>14F13B*</b>	<b>14F17B*</b>

14F Filter Dimensions		
<b>A</b> 1.69 (43)	<b>B</b> 1.53 (39)	<b>C</b> .39 (10)
<b>D</b> 3.82 (97)	<b>D†</b> 3.87 (99)	<b>E</b> 4.21 (107)
<b>E†</b> 4.26 (108)	<b>F</b> 1.60 (41)	

Standard part numbers shown bold.  
 For other models refer to ordering information below.  
 † For polycarbonate bowl see Caution on page 1.  
 § SCFM = Standard cubic feet per minute at 90 PSIG inlet and 5 PSIG pressure drop.

Inches (mm)  
 † With Automatic Pulse Drain.

**Ordering Information**

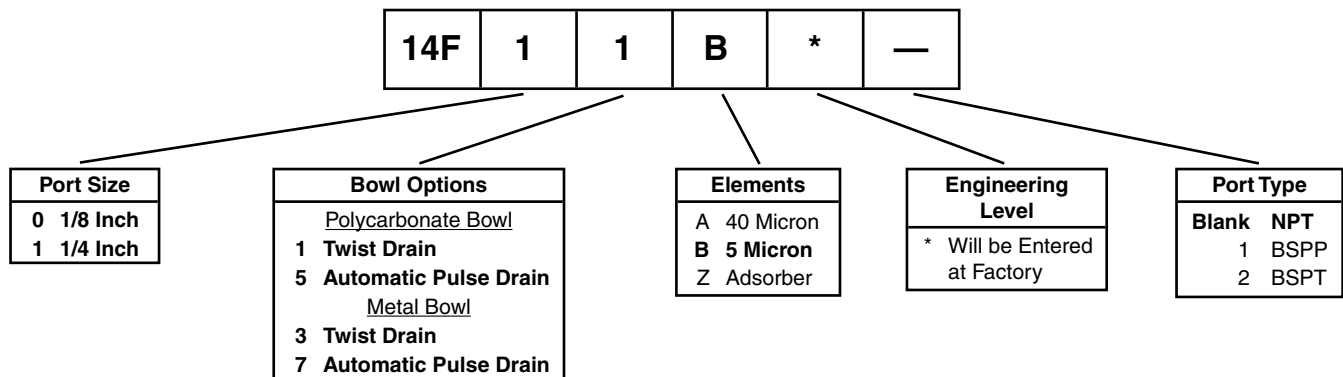

NOTE: BOLD OPTIONS ARE STANDARD.

Technical Information

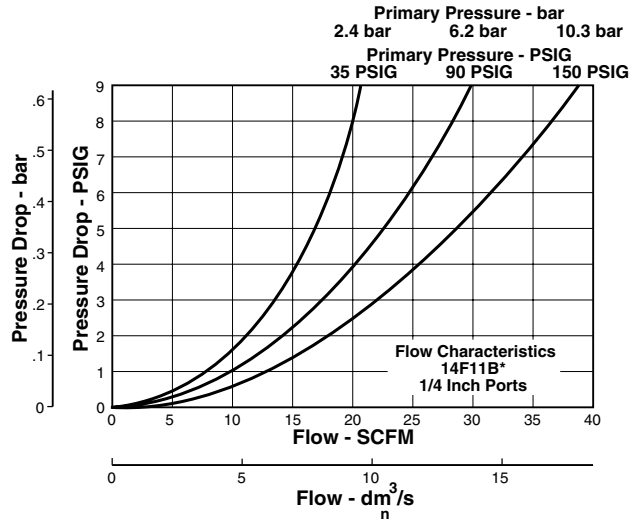
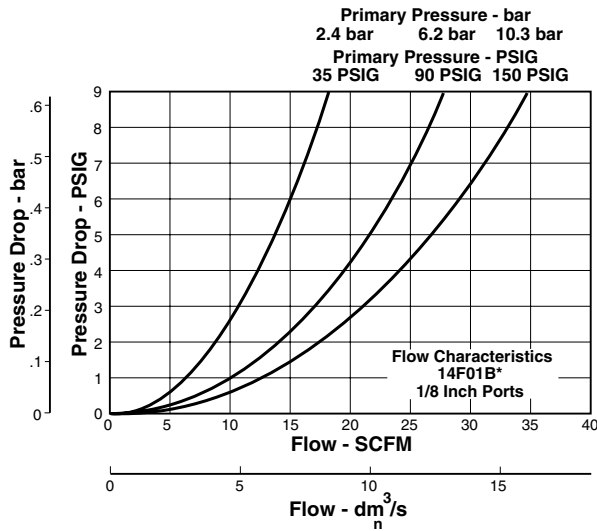

14F Filter Kits & Accessories

- Bowl Kits –
  - Poly Bowl –
    - Automatic Pulse Drain ..... PS408P
    - Twist Drain ..... PS404P
  - Metal Bowl –
    - Automatic Pulse Drain ..... PS451P
    - Twist Drain ..... PS447BP
- Filter Element Kits –
  - 40 Micron ..... PS401P
  - 5 Micron ..... PS403P
  - 5 Micron Cartridge Kit ..... PS407P
  - Adsorber ..... PS452P
- Mounting Bracket Kit ..... PS417BP

Specifications

- Automatic Pulse Drain Tube Barb ..... 1/8 Inch
- Bowl Capacity ..... 1 Ounce
- Port Threads ..... 1/8, 1/4 Inch
- Pressure & Temperature Ratings –
  - Polycarbonate Bowl ..... 0 to 150 PSIG (0 to 10.3 bar)  
32°F to 125°F (0°C to 52°C)
  - Metal Bowl ..... 0 to 250 PSIG (0 to 17.2 bar)  
32°F to 175°F (0°C to 80°C)
  - Automatic Pulse Drain ..... 10 to 250 PSIG (0.7 to 17.2 bar)  
at 125°F (52°C) or less
- Weight ..... 0.41 lb. (0.18 kg)

Materials of Construction

- Body ..... Zinc
- Bowls ..... Transparent Polycarbonate  
Metal (Zinc) Bowl w/o Sight Gauge
- Deflector, Element Holder & Baffle ..... Plastic
- Drains –
  - Twist Drain –
    - Body & Stem ..... Plastic
    - Seals ..... Nitrile
  - Automatic Pulse Drain –
    - Piston & Seals ..... Nitrile
    - Stem, Seat, Adaptor & Washers ..... Aluminum
- Filter Elements –
  - 5 Micron (Standard) ..... Plastic
  - 40 Micron (Optional) ..... Plastic
  - Adsorber (Optional) ..... Activated Charcoal
- Seals ..... Nitrile

**F504 Filters – Miniature**

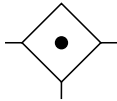

**Features**

- Excellent Water Removal Efficiency
- Unique Deflector Plate that Creates Swirling of the Air Stream Ensuring Maximum Water and Dirt Separation
- Easily Disassembled for Servicing Without the Use of Tools
- Interchangeable Twist and Automatic Pulse Drains
- High Flow: 22 SCFM<sup>§</sup>

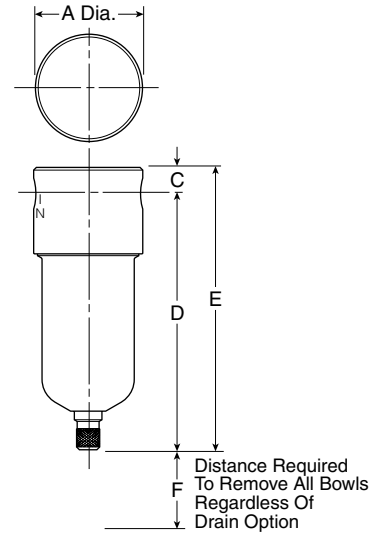

Port Size	NPT	
	Twist Drain	Automatic Pulse Drain
Polycarbonate Bowl †		
1/8"	<b>F504-01 AH</b>	<b>F504-01 AHS</b>
1/4"	<b>F504-02 AH</b>	<b>F504-02 AHS</b>
Metal Bowl without Sight Gauge		
1/8"	<b>F504-01 DH</b>	<b>F504-01 DHS</b>
1/4"	<b>F504-02 DH</b>	<b>F504-02 DHS</b>

F504 Filter Dimensions		
<b>A</b> 1.56 (39.7)	<b>C</b> 0.38 (9.5)	<b>D</b> 3.78 (96)
<b>D†</b> 3.62 (92)	<b>E</b> 4.16 (105.6)	<b>E†</b> 4.00 (101.6)
<b>F</b> .75 (77)	<b>F†</b> .75 (77)	

Standard part numbers shown bold.  
 For other models refer to ordering information below.  
 † For polycarbonate bowl see Caution on page 1.  
 § SCFM = Standard cubic feet per minute at 90 PSIG inlet and 5 PSIG pressure drop.

Inches (mm)  
 † With Metal Bowl

**Ordering Information**

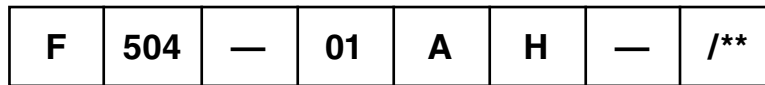

<b>Port Threads</b> — NPT G BSPP	<b>Port Size</b> 01 1/8 Inch 02 1/4 Inch	<b>Bowl</b> A Polycarbonate D Metal	<b>Elements</b> G 5 Micron H 20 Micron	<b>Drains and Options</b> <b>Blank</b> Manual Twist Drain S Automatic Pulse Drain X11 No Internal Parts X33* Polyurethane Bowl X64 Fluorocarbon Seals X67 With Mounting Bracket	<b>Engineering Change Designer</b> Will be entered at factory.
--	--	---	--	---	---

\* Add .65" to overall length.

NOTE: BOLD OPTIONS ARE STANDARD.

Technical Information

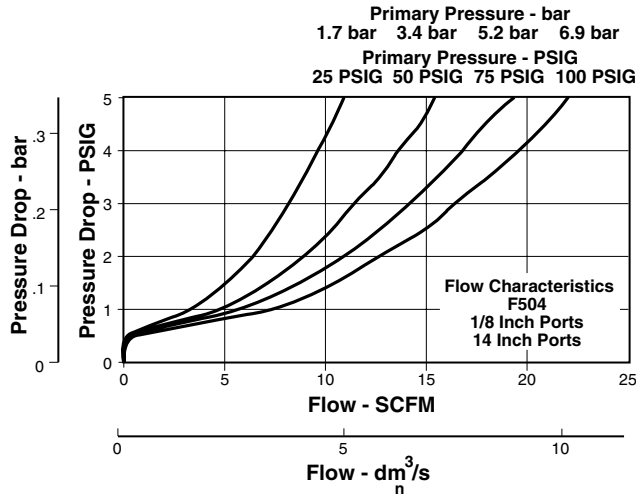

F504 Filter Kits & Accessories

Bowl Kits –

- Metal (D) .....BK505Y
- Metal (D) with Automatic Pulse Drain..... BK505SY
- Polycarbonate (A) .....BK504Y
- Polycarbonate (A) with Automatic Pulse Drain..... BK504SY

Drain Kits –

- Automatic Pulse Drain ..... RK504SY
- Manual Twist Drain ..... SA600Y7-1

Filter Element Kits –

- 5 Micron (All) ..... EK504VY
- 20 Micron (All) ..... EK504Y

Mounting Bracket Kit ..... Must be Ordered with Filter

Specifications

- Bowl Capacity ..... 1 Ounce
- Port Threads ..... 1/8, 1/4 Inch
- Pressure & Temperature Ratings –
  - Polycarbonate Bowl ..... 0 to 150 PSIG (0 to 10.2 bar)  
40°F to 125°F (4.4°C to 52°C)
  - Metal Bowl..... 0 to 300 PSIG (0 to 20.4 bar)  
40°F to 180°F (4.4°C to 82.2°C)
  - With Automatic Pulse Drain ..... 175 PSIG Max. Press. (11.9 bar)
- Weight
  - Polycarbonate Bowl ..... 0.3 lb. (0.14 kg) / Unit  
7 lb. (3.18 kg) / 24-Unit Master Pack
  - Metal Bowl..... 0.5 lb. (0.23 kg) / Unit  
12 lb. (5.44 kg) / 24-Unit Master Pack

Materials of Construction

- Body ..... Aluminum
- Bowls ..... Polycarbonate  
Metal (Zinc)
- Drains ..... Brass
- Filter Elements ..... Polypropylene
- Seals ..... Nitrile

( ) = Bowl Type

## 10F Coalescing Filters – Miniature

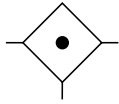

### Features

- Removes liquid aerosols and sub-micron particles.
- Liquids gravitate to the bottom of the element and will not re-enter the airstream.
- Oil free air for critical applications, such as air gauging and pneumatic instrumentation and controls.
- Interchangeable twist and automatic pulse drains.
- Grade 6 element, 99.97% DOP efficiency.
- High Flow: Grade 6 Element  
 1/8" – 17 SCFM<sup>§</sup>  
 1/4" – 20 SCFM<sup>§</sup>  
 Grade 10 Element  
 1/8" – 19 SCFM<sup>§</sup>  
 1/4" – 24 SCFM<sup>§</sup>

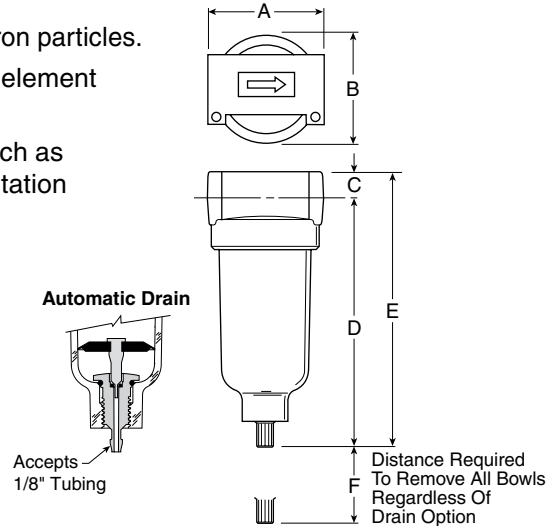

Port Size	NPT	
	Twist Drain	Automatic Pulse Drain
Poly Bowl †		
1/8"	<b>10F01E*</b>	<b>10F05E*</b>
1/4"	<b>10F11E*</b>	<b>10F15E*</b>
Metal Bowl without Sight Gauge		
1/8"	<b>10F03E*</b>	<b>10F07E*</b>
1/4"	<b>10F13E*</b>	<b>10F17E*</b>

10F Coalescing Filter Dimensions		
<b>A</b> 1.69 (43)	<b>B</b> 1.56 (39,6)	<b>C</b> 0.39 (10)
<b>D</b> 3.82 (97)	<b>D†</b> 3.67 (93)	<b>E</b> 4.21 (107)
<b>E†</b> 4.06 (103)	<b>F</b> 1.60 (41)	

Inches (mm)

† With Automatic Pulse Drain.

Standard part numbers shown bold, with Grade 6 Elements (for Grade 10 Elements, replace "E" with "H" in the 6th position). For other models refer to ordering information below.

† For polycarbonate bowl see Caution on page 1.

§ SCFM = Standard cubic feet per minute at 90 PSIG inlet and 5 PSIG pressure drop.

## Ordering Information

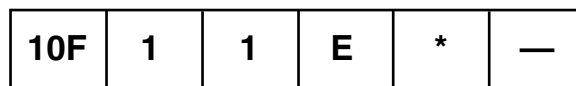

Port Size
0 1/8 Inch
1 1/4 Inch

Bowl Options
<u>Polycarbonate Bowl</u>
<b>1 Twist Drain</b>
<b>5 Automatic Pulse Drain</b>
<u>Metal Bowl</u>
<b>3 Twist Drain</b>
<b>7 Automatic Pulse Drain</b>

Elements
<b>E Grade 6</b>
<b>H Grade 10</b>

Engineering Level
* Will be Entered at Factory

Port Type
<b>Blank NPT</b>
1 BSPP
2 BSPT

NOTE: BOLD OPTIONS ARE STANDARD.



Technical Information

Grade 6

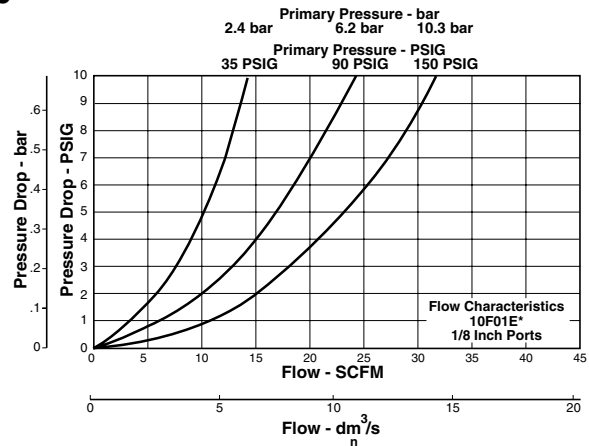
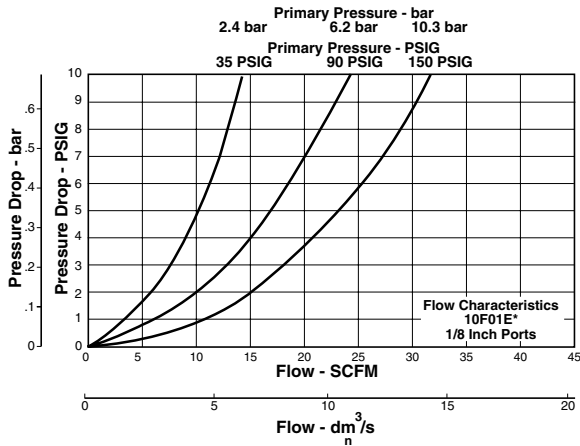

Grade 10

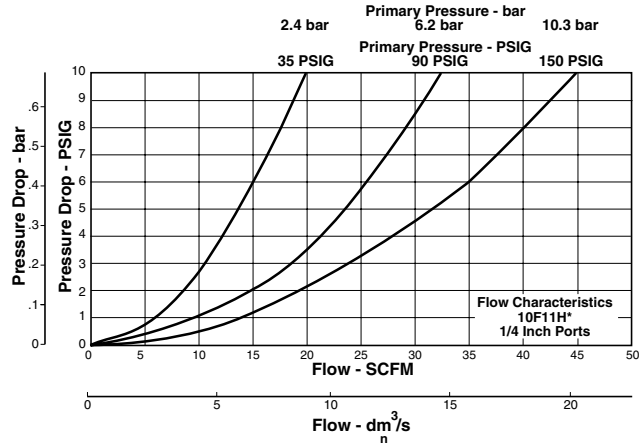
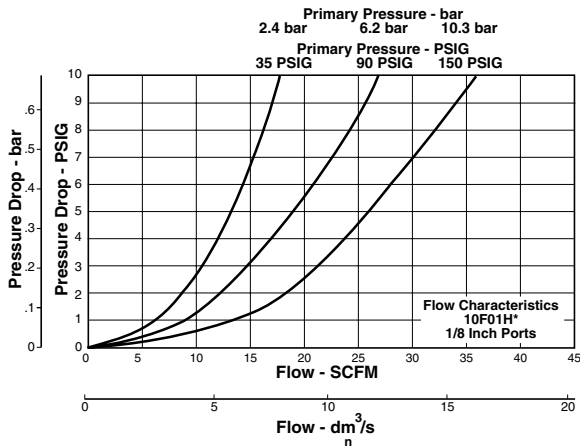

10F Coalescing Filter Kits & Accessories

Bowl Kits –

- Poly Bowl – Automatic Pulse Drain .....PS408P
- Twist Drain .....PS404P
- Metal Bowl –Automatic Pulse Drain ..... PS451P
- Twist Drain .....PS447BP

- Filter Element Kits – Grade 6 (Standard).....PS446P
- Grade 10 (Optional) .....PS456P

- Mounting Bracket Kit .....PS417BP

Specifications

- Automatic Pulse Drain Tube Barb..... 1/8 Inch
- Bowl Capacity ..... 1 Ounce
- Operation –

  - Normal Operating Pressure Drop .....2 PSIG
  - Maximum Recommended Pressure Drop ..... 10 PSIG (Element should be replaced)

- Port Threads ..... 1/8, 1/4 Inch
- Pressure & Temperature Ratings –

  - Polycarbonate Bowl – 0 to 150 PSIG (0 to 10.3 bar)
  - 32°F to 125°F (0°C to 52°C)
  - Metal Bowl – 0 to 250 PSIG (0 to 17.2 bar)
  - 32°F to 175°F (0°C to 80°C)

- Weight ..... 0.41 lb. (0.18 kg)

Materials of Construction

- Body ..... Zinc
- Bowls ..... Transparent Polycarbonate
- Metal (Zinc) Without Sight Gauge
- Drains – Twist Drain –

  - Body & Stem ..... Plastic
  - Seals .....Nitrile

- AutomaticPulse Drain –

  - Piston & Seals.....Nitrile
  - Stem, Seat, Adaptor & Washers..... Aluminum

- Element Holder ..... Plastic
- Filter Element –

  - Borosilicate & felt glass fibers 99.97% DOP efficiency
  - Largest Aerosol Particle Passed (Grade 6) ..... 0.75 Micron
  - Largest Solid Particle Passed (Grade 6)..... 0.30 Micron

- Seals .....Nitrile

Media Specifications

Grade	D.O.P. Coalescing Efficiency 0.3 to 0.6 Micron Particles	Maximum Oil Carryover <sup>1</sup> PPM w/w	Pressure Drop (PSID) <sup>2</sup> @ Rated Flow		Particulate Micron Rating
			Media Dry	Media Wet With 10-20 wt. oil	
6	99.97%	0.008	1.0	2-3	0.01
10	95%	0.85	0.5	0.5	0.7

<sup>1</sup> Tested per BCAS 860900 at 40 ppm inlet.

<sup>2</sup> Add dry + wet for total pressure drop.

D.O.P. = Dioctylphthalate

## F501, F507 Coalescing Filters – Miniature

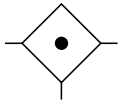

### Features

- Removes Liquid Aerosols and Sub-micron Particles.
- Liquids Gravitate to the Bottom of the Element and Will Not Re-enter the Airstream.
- Oil Free Air for Critical Applications, such as Air Gauging and Pneumatic Instrumentation and Controls.
- Interchangeable Twist and Automatic Pulse Drains.
- Grade 6 Element, 99.97% DOP Efficiency.
- High Flow: Grade 6 Element – 8 SCFM<sup>§</sup>  
Grade 10 Element – 10 SCFM<sup>§</sup>

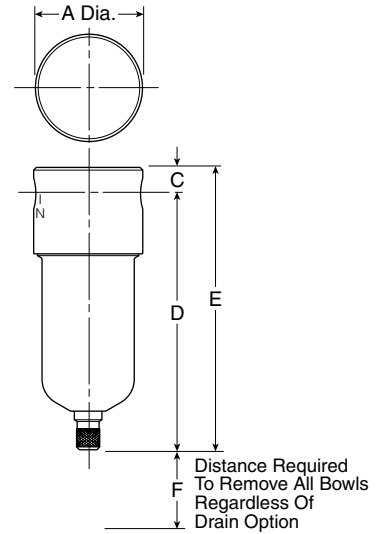

Port Size	NPT	
	Grade 6	Grade 10
Polycarbonate Bowl, Manual Twist Drain †		
1/8"	<b>F501-01 AH</b>	<b>F507-01 AO</b>
1/4"	<b>F501-02-AH</b>	<b>F507-02 AO</b>
Metal Bowl without Sight Gauge, Manual Twist Drain		
1/8"	<b>F501-01 DH</b>	<b>F507-01 DO</b>
1/4"	<b>F501-02-DH</b>	<b>F507-02 DO</b>

F501 / F507 Coalescing Filter Dimensions		
<b>A</b> 1.56 (39.7)	<b>B</b> .038 (9.5)	<b>D</b> 3.78 (96)
<b>D†</b> 3.62 (92)	<b>E</b> 4.16 (105.6)	<b>E†</b> 4.00 (101.6)
<b>F</b> .75 (77)	<b>F†</b> .75 (77)	

Standard part numbers shown bold).

For other models refer to ordering information below.

† For polycarbonate bowl see Caution on page 1.

§ SCFM = Standard cubic feet per minute at 100 PSIG inlet and 1.0 PSIG Grade 6, .5 PSIG Grade 10 pressure drop.

Inches (mm)

† With Metal Bowl

## Ordering Information

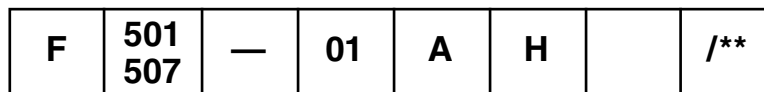

Port Threads
— NPT
G BSPP

Port Size
01 1/8 Inch
02 1/4 Inch

Bowl
A Polycarbonate
D Metal

Elements
F501
H Grade 6
F507
O Grade 10

Drains and Options	
Blank	Manual Twist Drain
S	Automatic Pulse Drain
X33*	Polyurethane Bowl
X64	Fluorocarbon Seals
X67	With Mounting Bracket

Engineering Change Designator
Will be entered at factory.

\* Add .65" to overall length.

NOTE: BOLD OPTIONS ARE STANDARD.

Technical Information

Coalescing Filter Flow Ratings in SCFM

F501 Flow measured at 100 PSIG inlet pressure and 1.0 PSIG pressure drop.

F507 Flow measured at 100 PSIG inlet pressure and 0.5 PSIG pressure drop.

For Inlet Pressures other than 100 PSIG

Inlet Pressure	F501-H	F507-O	Inlet Pressure	F501H	F507-O
10	1.7	2.2	160	12.2	15.2
20	2.4	3.0	170	12.9	16.1
30	3.1	3.9	180	13.6	17.0
40	3.8	4.8	190	14.3	17.8
50	4.5	5.6	200	15.0	18.7
60	5.2	6.5	210	15.7	19.6
70	5.9	7.4	220	16.4	20.5
80	6.6	8.3	230	17.1	21.3
90	7.3	9.1	240	17.8	22.2
100	8.0	10.0	250	18.5	23.1
110	8.7	10.9	260	19.2	23.9
120	9.4	11.7	270	19.9	24.8
130	10.1	12.6	280	20.6	25.7
140	10.8	13.5	290	21.3	26.6
150	11.5	14.4	300	21.9	27.4
Polycarbonate Bowl Limit 150 PSIG			Mini Zinc Bowl Only Limit 300 PSIG		

F501, F507 Filter Kits & Accessories

Bowl Kits –

- Polycarbonate (A) .....BK504Y
- Metal (D) .....BK505Y
- Polycarbonate (A) with Automatic Pulse Drain..... BK504SY
- Metal (D) with Automatic Pulse Drain..... BK505SY

Drain Kits –

- Manual Twist Drain ..... SA600Y7-1
- Automatic Pulse Drain ..... RK504SY

Filter Element Kits –

- Grade 6 .....EKF501H
- Grade 10 ..... EKF507

Mounting Bracket Kit ..... Must be Ordered with Filter

Specifications

Bowl Capacity ..... 1 Ounce

Port Threads..... 1/8, 1/4 Inch

Pressure & Temperature Ratings –

- Polycarbonate Bowl ..... 0 to 150 PSIG (0 to 10.2 bar)  
40°F to 125°F (4.4°C to 52°C)
- Metal Bowl.....0 to 300 PSIG (0 to 20.4 bar)  
40°F to 180°F (4.4°C to 82.2°C)
- With Automatic Pulse Drain..... 175 PSIG Max. Press. (11.9 bar)

( ) = Bowl Type

Weight

- Polycarbonate Bowl ..... 0.3 lb. (0.14 kg) / Unit  
7 lb. (3.18 kg) / 24-Unit Master Pack
- Metal Bowl..... 0.5 lb. (0.23 kg) / Unit  
12 lb. (5.44 kg) / 24-Unit Master Pack

Materials of Construction

- Body ..... Aluminum
- Bowls ..... Polycarbonate  
Metal (Zinc)
- Drains ..... Brass
- Filter Elements ..... Polypropylene
- Seals ..... Nitrile

Media Specifications

Grade	D.O.P. Coalescing Efficiency 0.3 to 0.6 Micron Particles	Maximum Oil Carryover <sup>1</sup> PPM w/w	Pressure Drop (PSID) <sup>2</sup> @ Rated Flow		Particulate Micron Rating
			Media Dry	Media Wet With 10-20 wt. oil	
6	99.97%	0.008	1.0	2-3	0.01
10	95%	0.85	0.5	0.5	0.7

<sup>1</sup> Tested per BCAS 860900 at 40 ppm inlet.

<sup>2</sup> Add dry + wet for total pressure drop.

D.O.P. = Dioctylphthalate



**14R Regulators – Miniature**

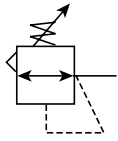

**Features**

- Unbalanced poppet standard.
- Solid control piston with lip seal for extended life.
- Non-rising adjusting knob.
- Compact, 2.88 inch (73,2mm) high by 1.65 inch (42mm) wide.
- Easily serviced.
- High Flow: 1/8" – 13 SCFM<sup>§</sup>  
 1/4" – 15 SCFM<sup>§</sup>

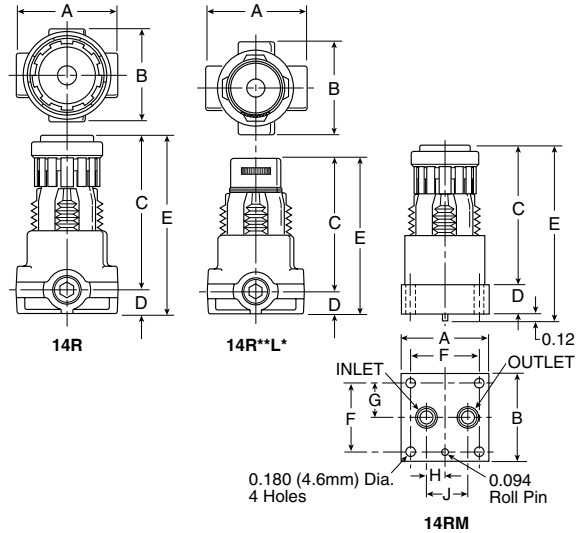

Port Size	NPT
Without Gauge	
1/8"	<b>14R013F*</b>
1/4"	<b>14R113F*</b>
With Gauge	
1/8"	<b>14R018F*</b>
1/4"	<b>14R118F*</b>

14R Regulator Dimensions					
	A	B	C	D	E
<b>14R</b>	1.65 (42)	1.56 (40)	2.50 (63,5)	0.38 (10)	2.88 (73)
<b>14R**L*</b>	1.65 (42)	1.56 (40)	2.28 (57,9)	0.38 (10)	2.68 (68)
<b>14RM</b>	A	B	C	D	E
	1.50 (38)	1.50 (38)	2.36 (60)	0.50 (13)	2.98 (73)
	F	G	H	J	
	1.188 (30)	0.594 (15)	0.325 (8)	0.725 (18)	

Standard part numbers shown bold. For other models refer to ordering information below.

NOTE: 1.218 Dia. (31mm) hole required for panel mounting.

§ SCFM = Standard cubic feet per minute at 100 PSIG inlet, 90 PSIG no flow secondary setting and 10 PSIG pressure drop.

Inches (mm)

**Ordering Information**



Port Size	Pressure Range	Relief	Port Type	Options	Preset / Pressure Limited
<b>0</b> 1/8 Inch Pipe, 1/8 Inch Gauge Port	<b>Without Gauge</b> Yellow Knob Black Knob	<b>F</b> Relieving	<b>Blank</b> NPT	<b>Blank</b> No Options	<b>Blank</b> None
<b>1</b> 1/4 Inch Pipe, 1/8 Inch Gauge Port	10 30 PSIG B0 30 PSIG	G Non-Relieving	1 BSPP	L <sup>†</sup> Preset Non-Adjustable	XXX* Preset
<b>B</b> 1/4 Inch Pipe, 1/4 Inch Gauge Port	11 60 PSIG B1 60 PSIG	H Low Temp. Relieving	2 BSPT	P <sup>†</sup> Preset Adjustable	XXX* Pressure Limited
<b>C</b> 1/8 Inch Pipe, No Gauge Port	12 15 PSIG B2 15 PSIG	J Low Temp. Non-Relieving		S <sup>†</sup> Pressure Limiter Max. Adjustable	
<b>M</b> Manifold Mounting	<b>13 125 PSIG</b> B3 125 PSIG			T <sup>†</sup> Pressure Limiter Max. Non-Adjustable	
	<b>With Gauge</b>				
	15 30 PSIG B5 30 PSIG				
	16 60 PSIG B6 60 PSIG				
	17 15 PSIG B7 15 PSIG				
	18 125 PSIG B8 125 PSIG				

**Engineering Level**  
 \* Will be Entered at Factory

† Inlet Pressure is 100 PSIG. For other pressures, contact factory.

\* Available Preset / Pressure Limited Range, 10 to 90 PSIG in 5 PSIG increments. For higher pressures, contact factory.  
 (Example: 065 = 65 PSIG)

**Spring Type by Preset / Limited Pressure:**  
 For Preset / Limited Pressure 10 to 25 use 30 PSI Spring  
 For Preset / Limited Pressure 26 to 50 use 60 PSI Spring  
 For Preset / Limited Pressure 51 to 90 use 125 PSI Spring

**NOTE: BOLD OPTIONS ARE STANDARD.**

Technical Information

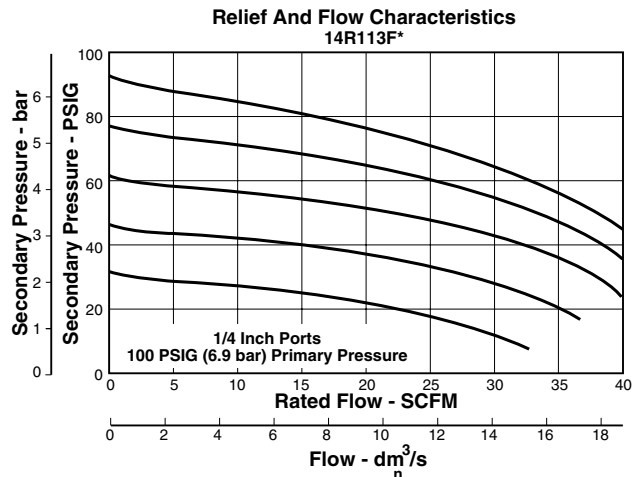
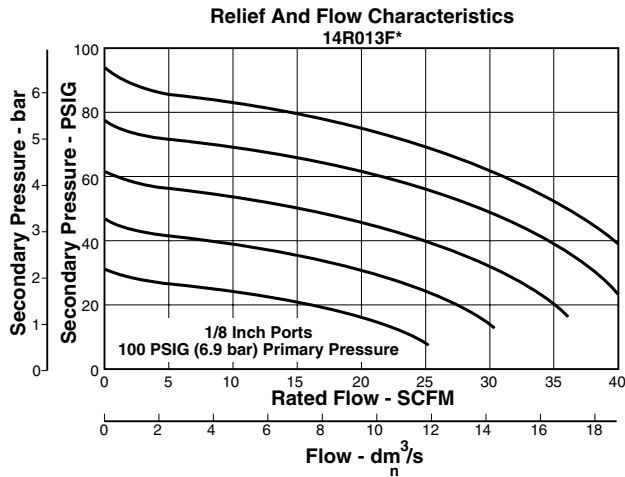

**CAUTION:**

**REGULATOR PRESSURE ADJUSTMENT** – The working range of knob adjustment is designed to permit outlet pressures within their full range. Pressure adjustment beyond this range is also possible because the knob is not a limiting device. This is a common characteristic of most industrial regulators, and limiting devices may be obtained only by special design.

For best performance, regulated pressure should always be set by increasing the pressure up to the desired setting.

<p><b>⚠ WARNING</b></p> <p><b>Product rupture can cause serious injury.</b>  <b>Do not connect regulator to bottled gas.</b>  <b>Do not exceed maximum primary pressure rating.</b></p>
---

**14R Regulator Kits & Accessories**

- Body Service Kit – Unbalanced .....PS424BP
- Bonnet Assembly Kit ..... L01369
- Gauges – 30 PSIG, 1/8" NPT (0 to 2.1 bar) ..... K4515N18030
- 60 PSIG, 1/8" NPT (0 to 4.1 bar) ..... K4515N18060
- 160 PSIG, 1/8" NPT (0 to 11.0 bar).....K4515N18160
- 60 PSIG, 1/4" NPT (0 to 4.1 bar)..... K4520N14060
- 160 PSIG, 1/4" NPT (0 to 11.0 bar).....K4520N14160
- Mounting Bracket Kit (Includes Panel Mount Nut) ..... PS417BP
- Panel Mount Nuts – Plastic.....P78652
- Metal.....P01531
- Service Kits – Non-Relieving .....PS422P
- Relieving .....PS423P
- Springs – 1-15 PSIG Range (Yellow) ..... P01176
- 1-30 PSIG Range (Black) ..... P01175
- 1-60 PSIG Range (White).....P01174
- 2-125 PSIG Range (Gold)..... P01173

**Specifications**

- Gauge Ports (2) ..... 1/8 or 1/4 Inch  
(Can be used for Full Flow)
- Port Threads ..... 1/8, 1/4 Inch
- Pressure & Temperature Ratings – 0 to 300 PSIG (0 to 20.7 bar)  
32°F to 125°F (0°C to 52°C)
- Secondary Pressure Ranges –
- Standard Pressure .....2 to 125 PSIG (0 to 8.6 bar)
- Medium Pressure .....1 to 60 PSIG (0 to 4.1 bar)
- Medium Pressure .....1 to 30 PSIG (0 to 2.1 bar)
- Low Pressure .....1 to 15 PSIG (0 to 1 bar)
- Weight – 14R, 14RM, 14\*\*L\* ..... 0.3 lb. (0.14 kg)

**Materials of Construction**

- Adjusting Nut .....Brass
- Adjusting Stem & Spring ..... Steel
- Body ..... Zinc
- Bonnet, Seat, Piston & Valve Poppet ..... Plastic
- Seals .....Nitrile

## P3A-R Regulators – Miniature

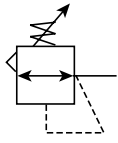

### Features

- Lightweight plastic body.
- Non-rising adjusting knob.
- Solid control piston with lip seal for extended life.
- Unbalanced poppet standard.
- Two full flow 1/8" gauge ports.
- Reverse flow capability.
- High Flow: 1/8" – 18 SCFM<sup>§</sup>

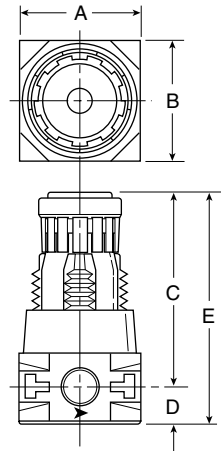

Port Size	NPT
Without Gauge	
1/8"	<b>P3A-RN91YNN</b>
1/4"	<b>P3A-RN92YNN</b>
With Gauge	
1/8"	<b>P3A-RN91YGN</b>
1/4"	<b>P3A-RN92YGN</b>

P3A-R Regulator Dimensions		
A	B	C
1.57 (40)	1.57 (40)	2.46 (63)
D	E	
0.46 (12)	2.92 (74)	

Inches (mm)

Standard part numbers shown bold. For other models refer to ordering information below.

NOTE: 1.218 Dia. (31mm) hole required for panel mounting.

§ SCFM = Standard cubic feet per minute at 100 PSIG inlet, 90 PSIG no flow secondary setting and 10 PSIG pressure drop.

## Ordering Information

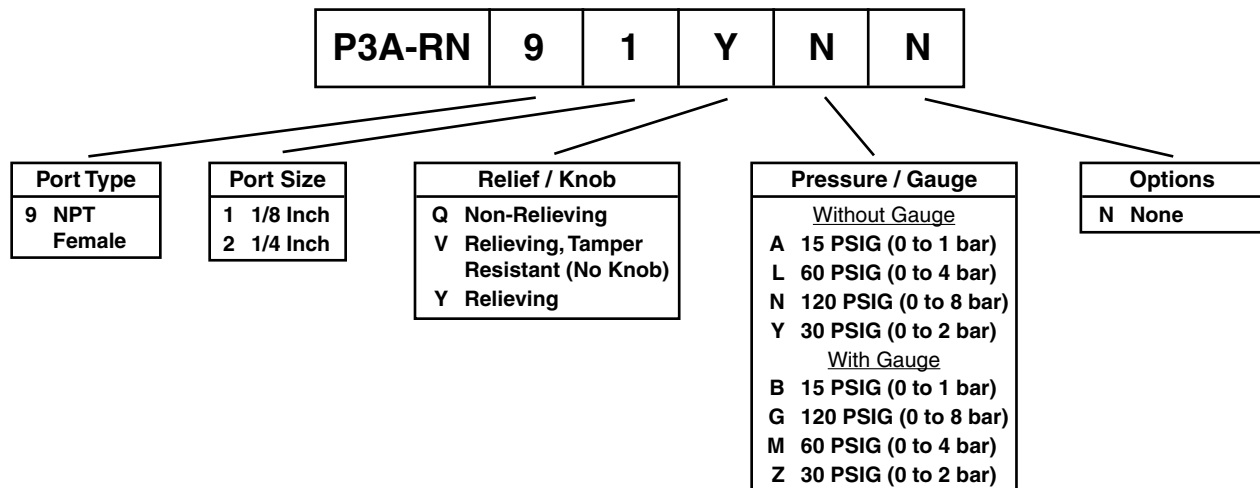

NOTE: BOLD OPTIONS ARE STANDARD.

Technical Information

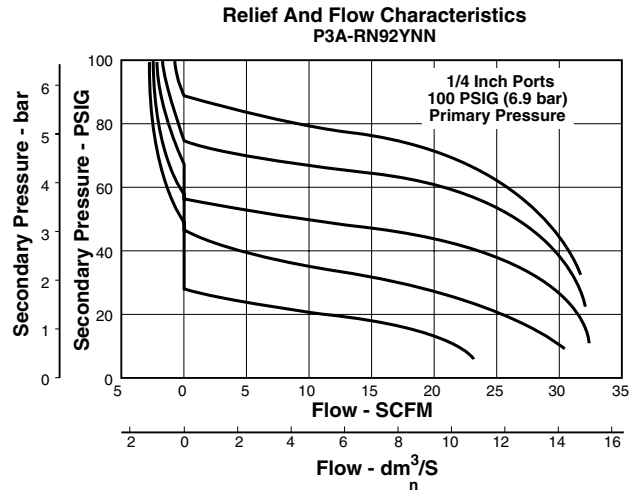
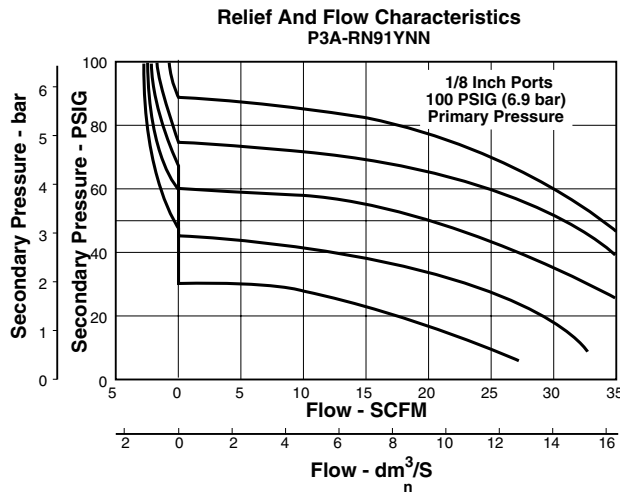

**CAUTION:**

**REGULATOR PRESSURE ADJUSTMENT** – The working range of knob adjustment is designed to permit outlet pressures within their full range. Pressure adjustment beyond this range is also possible because the knob is not a limiting device. This is a common characteristic of most industrial regulators, and limiting devices may be obtained only by special design.

For best performance, regulated pressure should always be set by increasing the pressure up to the desired setting.

**⚠ WARNING**

**Product rupture can cause serious injury.  
Do not connect regulator to bottled gas.  
Do not exceed maximum primary pressure rating.**

**P3A-R Regulator Kits and Accessories**

- Gauges** – 30 PSIG, 1/8" NPT (0 to 2.1 bar) ..... K4515N18030
- 60 PSIG, 1/8" NPT (0 to 4.1 bar) ..... K4515N18060
- 160 PSIG, 1/8" NPT (0 to 11.0 bar).....K4515N18160
- Panel Mount Nut** .....P78652
- Mounting Bracket Kit** .....PS417BP
- Service Kits** – Piston Non-Relieving..... PS422
- Piston Relieving..... PS423
- Poppet Service Kits – Balanced.....PS425B
- Unbalanced ..... PS424B
- Springs** – 1-15 PSIG Spring (Yellow)..... P01176
- 1-30 PSIG Spring (Black)..... P01175
- 1-60 PSIG Spring (White) .....P01174
- 5-110 PSIG Spring (Gold) ..... P01173

**Specifications**

<b>Gauge Ports (2)</b> .....	1/8 Inch
<b>Operating Pressure Range –</b>	<b>PSIG      bar</b>
<b>Primary –</b> Maximum	120      8.3
<b>Secondary –</b>	
15 PSIG Spring    Minimum	1        0.07
Maximum	15      1.0
30 PSIG Spring    Minimum	6        0.4
Maximum	30      2.1
60 PSIG Spring    Minimum	6        0.4
Maximum	60      4.1
110 PSIG Spring    Minimum	6        0.4
Maximum	110     7.6
<b>Operating Temperature Range</b> .....	32°F to 125°F (0°C to 52°C)
<b>Port Threads</b> .....	1/8, 1/4 Inch
<b>Weight</b> .....	0.23 lb. (0.10 kg.)

**Materials of Construction**

- Adjusting Nut** ..... Brass
- Adjusting Stem & Spring** ..... Steel
- Poppet Return Spring** ..... Stainless Steel
- Body** ..... Plastic
- Bonnet, Seat & Piston** ..... Plastic
- Seals** ..... Nitrile
- Valve Poppet** ..... Plastic & Nitrile

**P3A-W Regulators – Miniature (Water Service)**

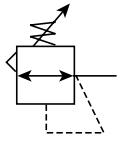

**Features**

- Lightweight plastic body.
- Constructed of F.D.A. listed materials.
- Unbalanced poppet standard.
- Non-rising adjusting knob.
- Compact, 2.96 inch (75 mm) high by 1.57 inch (40 mm) wide.
- Lightweight.
- Rolling diaphragm for superior performance and life.

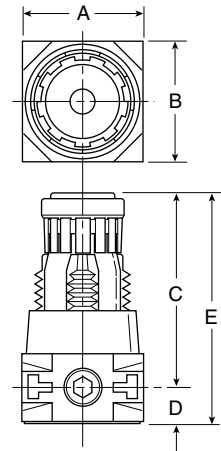

Port Size	NPT
Without Gauge	
1/8"	<b>P3A-WN91QNN</b>
1/4"	<b>P3A-WN92QNN</b>

Standard part numbers shown bold. For other models refer to ordering information below.

NOTE: 1.218 Dia. (31mm) hole required for panel mounting.

P3A-W Regulator Dimensions		
A	B	C
1.57 (40)	1.57 (40)	2.50 (64)
D	E	
0.46 (12)	2.96 (75)	

Inches (mm)

**Ordering Information**

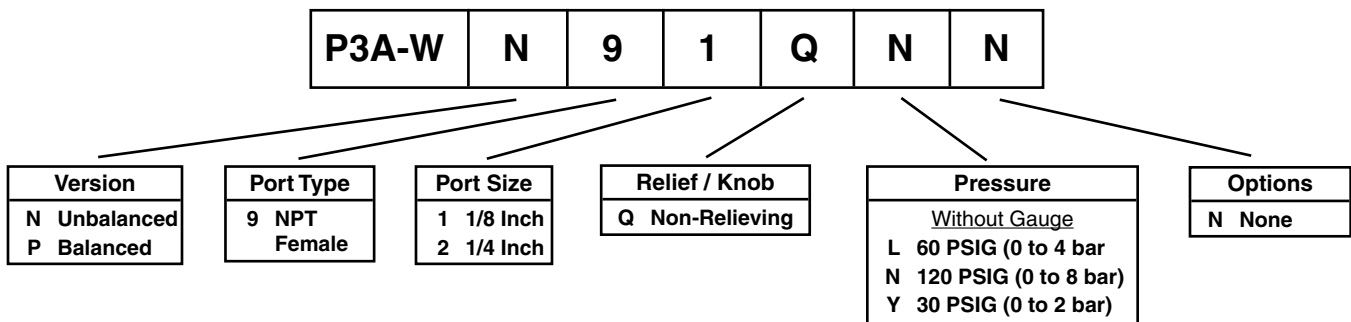

NOTE: BOLD OPTIONS ARE STANDARD.



# Technical Specifications – P3A-W

## Technical Information

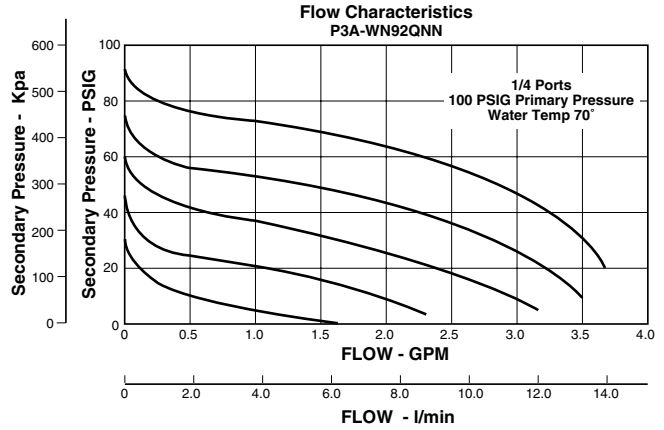
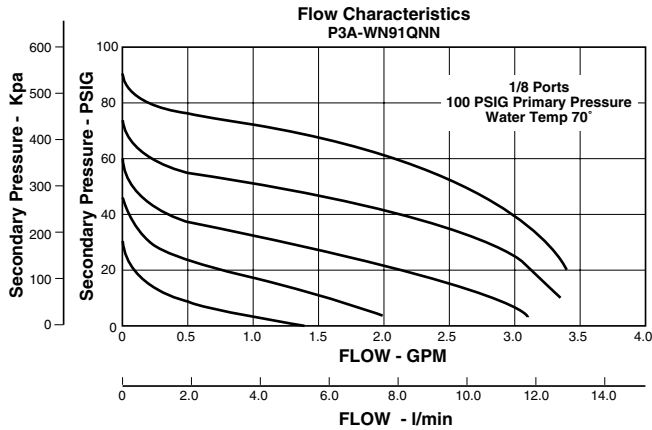

### CAUTION:

**REGULATOR PRESSURE ADJUSTMENT** – The working range of knob adjustment is designed to permit outlet pressures within their full range. Pressure adjustment beyond this range is also possible because the knob is not a limiting device. This is a common characteristic of most industrial regulators, and limiting devices may be obtained only by special design.

For best performance, regulated pressure should always be set by increasing the pressure up to the desired setting.

### ⚠ WARNING

**Product rupture can cause serious injury.  
Do not connect regulator to bottled gas.  
Do not exceed maximum primary pressure rating.**

### P3A-W Regulator Kits and Accessories

Panel Mount Nut .....	P78652
Mounting Bracket Kit .....	PS417BP
Service Kits – Piston Non-Relieving .....	PS422
Poppet Service Kits – Balanced.....	PS425B
Unbalanced.....	PS424B
Springs – 1-30 PSIG Spring.....	P78659B
1-60 PSIG Spring.....	P00411
5-125 PSIG Spring.....	P78660B

### Specifications

Gauge Ports (2) .....	1/8 Inch
(Can be used for full flow)	
Pressure Rating –	
Maximum Inlet Pressure 150 PSIG.....	(10.0 bar)
Port Threads .....	1/8, 1/4 Inch
Temperature Rating .....	Water 40°F to 125°F (4°C to 52°C)
Weight .....	0.23 lb. (0.10 kg.)

### Materials of Construction

Adjusting Nut .....	Brass
Adjusting Stem .....	Brass
Body .....	Plastic
Bonnet, Seat & Piston .....	Plastic
Diaphragm .....	Santoprene
Seals .....	Buna N or Thermo Plastic Elastomer
Springs .....	Stainless Steel
Valve Poppet .....	Plastic / Nitrile

**R45 Regulators – Miniature (Air / Water Service)**

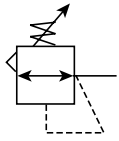

**Features**

- Lightweight plastic body.
- Constructed with a combination of N.S.F. and F.D.A. approved materials.
- Unbalanced poppet standard.
- Non-rising, push-to-lock adjusting knob.
- Compact, 3.43 inch (87.1mm) high by 2.06 inch (52.3mm) wide.
- Lightweight.
- Diaphragm operated.

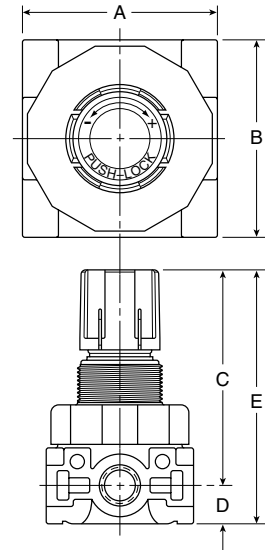

<b>Port Size</b>	<b>NPT</b>
Relieving, 0-125 Reduced Pressure, Without Gauge	
1/4"	<b>R45-02C</b>
3/8"	<b>R45-03C</b>

<b>R45 Regulator Dimensions</b>		
<b>A</b>	<b>B</b>	<b>C</b>
2.06 (52)	2.06 (52)	2.90 (74)
<b>D</b>	<b>E</b>	
0.53 (14)	3.43 (87)	

Standard part numbers shown bold. For other models refer to ordering information below.

NOTE: 1.218 Dia. (31mm) hole required for panel mounting.

Inches (mm)

**Ordering Information**

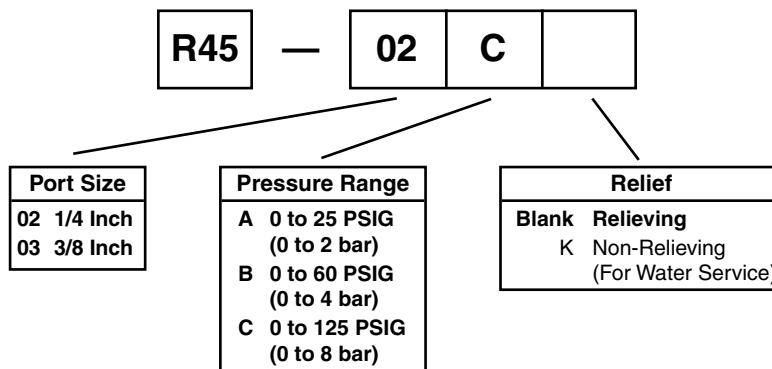

NOTE: BOLD OPTIONS ARE STANDARD.

Technical Information

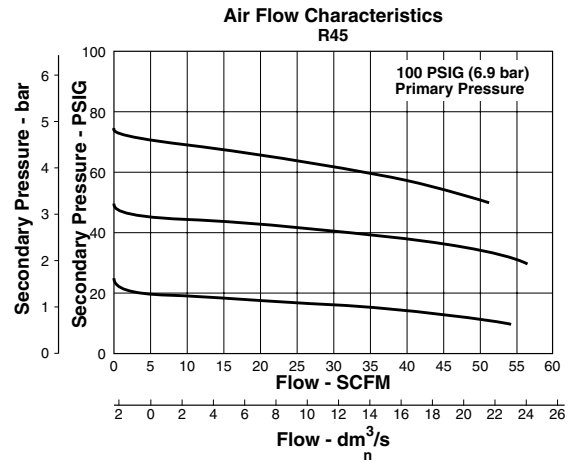
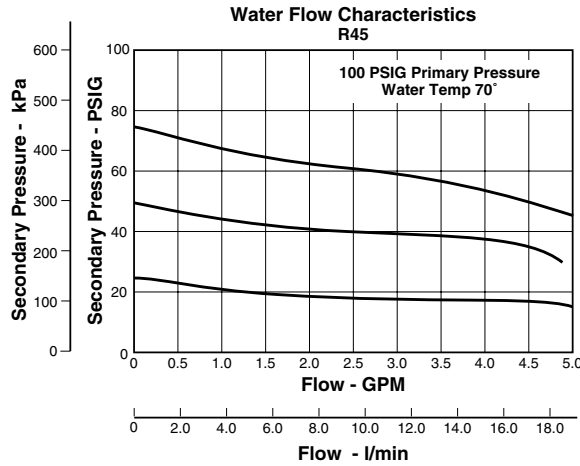

**CAUTION:**

**REGULATOR PRESSURE ADJUSTMENT** – The working range of knob adjustment is designed to permit outlet pressures within their full range. Pressure adjustment beyond this range is also possible because the knob is not a limiting device. This is a common characteristic of most industrial regulators, and limiting devices may be obtained only by special design.

For best performance, regulated pressure should always be set by increasing the pressure up to the desired setting.

**⚠ WARNING**

**Product rupture can cause serious injury.  
Do not connect regulator to bottled gas.  
Do not exceed maximum primary pressure rating.**

**R45 Regulator Kits and Accessories**

- Panel Mount Nut – Plastic ..... R05X51
- Aluminum ..... R05X51A
- Mounting Bracket and Nut ..... SA161X57
- Service Kits – Relieving ..... RKR45Y
- Non-Relieving ..... RKR45KY
- Springs – 0-25 PSIG Spring ..... SPR-46
- 0-60 PSIG Spring ..... SPR-47
- 0-125 PSIG Spring ..... SPR-48

**Specifications**

- Gauge Ports (2) ..... 1/4 Inch  
(Can be used for full flow)
- Pressure Rating –  
Maximum Inlet Pressure 150 PSIG.....(10.0 bar)
- Port Threads ..... 1/4, 3/8 Inch
- Temperature Rating ..... 40°F to 125°F (4°C to 52°C)
- Weight ..... 0.38 lb. (0.17 kg)

**Materials of Construction**

- Adjusting Screw ..... Steel
- Body ..... Acetal
- Bonnet and Seat ..... Acetal
- Diaphragm ..... Buna N
- Seals ..... Buna N
- Springs ..... Stainless Steel
- Valve Poppet ..... Buna N

## R364, R374 Regulators – Miniature

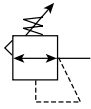

### Features

- High Flow and High Sensitivity
- Can be Used for Water Service
- Unbalanced Poppet Standard
- Diaphragm Operated for Fast Response
- Non-rising Adjusting Knob
- High Flow: 10 SCFM<sup>§</sup> (Air)  
1.25 GPM (Water)

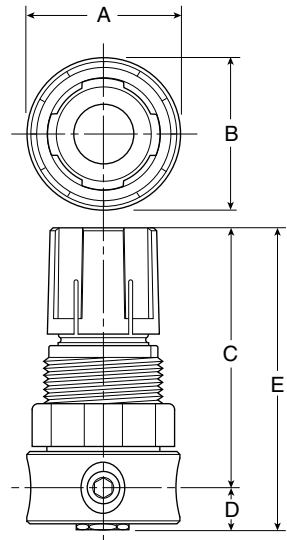

Port Size	NPT
<b>Brass</b>	
1/8"	<b>R364-01C</b>
1/4"	<b>R364-02C</b>
<b>Aluminum</b>	
1/8"	<b>R374-01C</b>
1/4"	<b>R374-02C</b>

R364, R374 Regulator Dimensions		
A	B	C
1.56 (39.7)	1.56 (39.7)	2.56 (65.1)
D	E	
0.50 (12.7)	3.06 (77.8)	

Standard part numbers shown bold.

For other models refer to ordering information below.

<sup>§</sup> SCFM = Standard cubic feet per minute at 100 PSIG inlet, 75 PSIG no flow secondary setting and 25% pressure drop.

NOTE: 1.250 Dia. (31.8mm) hole required for panel mounting.

Inches (mm)

## Ordering Information

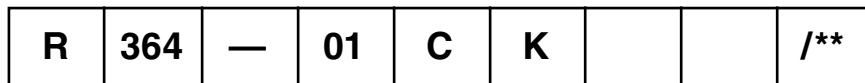

<b>Series</b> R364 Brass R374 Aluminum	<b>Port Threads</b> — NPT G BSPP	<b>Reduced Pressure Range</b> A 1-25 PSIG B 2-60 PSIG C 2-125 PSIG	<b>Options</b> G Gauge K Non-Relieving P Panel Mount Nut T Tamper Proof X64 Fluorocarbon O-Rings and Diaphragm X42 Constant Bleed Innervolve X21 High Flow Innervolve X10 Max. Pressure Limiting Adjusting Screw X82 Brass Spring Cage / Adjusting Screw	<b>Pressure Preset Options</b> Blank No Options +L Preset Non-Adjustable† +P Preset Adj.† +Q Preset Tamperproof Adjustable† +S Pressure Limiter Max. Adjustable† +T Pressure Limiter Max. Non-Adj.†	<b>Engineering Change Designator</b> Will be entered at factory.
<b>Port Size</b> 01 1/8 Inch 02 1/4 Inch		<b>Preset / Pressure Limited</b> Blank None XXX* Preset Pressure XXX* Pressure Limited		* Available Preset / Pressure Limited Range, 10 to 90 PSIG in 5 PSIG increments. For higher pressures, contact factory. (Example: 065 = 65 PSIG)	

NOTE: BOLD OPTIONS ARE STANDARD.

† Inlet Pressure is 100 PSIG. For other pressures, contact factory.

Technical Information

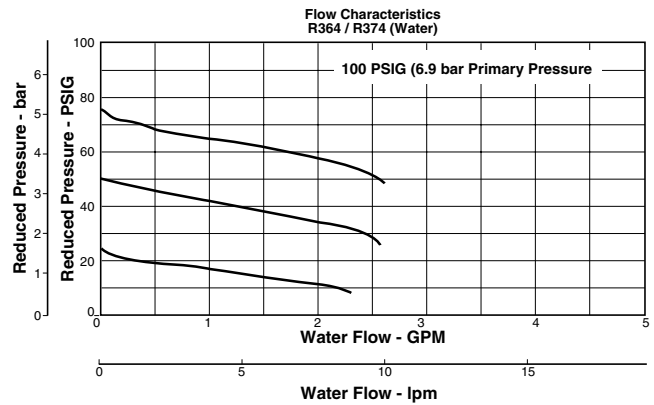
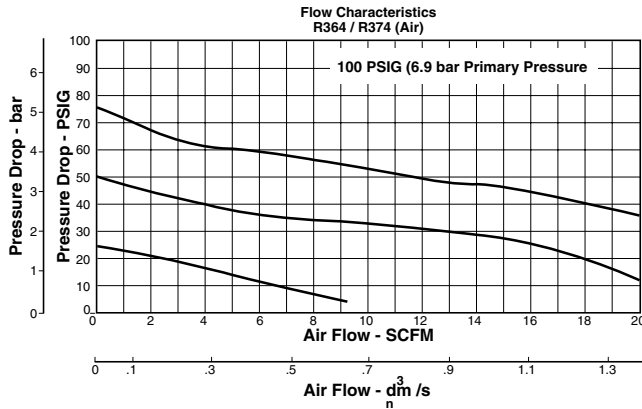

**CAUTION:**

**REGULATOR PRESSURE ADJUSTMENT** – The working range of knob adjustment is designed to permit outlet pressures within their full range. Pressure adjustment beyond this range is also possible because the knob is not a limiting device. This is a common characteristic of most industrial regulators, and limiting devices may be obtained only by special design.

For best performance, regulated pressure should always be set by increasing the pressure up to the desired setting.

**⚠ WARNING**

Product rupture can cause serious injury.  
Do not connect regulator to bottled gas.  
Do not exceed maximum primary pressure rating.

**R364, R374 Regulator Kits & Accessories**

- Gauges – 1-1/2" Dial Size, 1/8" Back Connection  
0 to 60 PSIG (0 to 400 kPa)..... K4515N18060
- 1-1/2" Dial Size, 1/8" Back Connection  
0 to 160 PSIG, (0 to 1100 kPa) .....K4515N18160

Mounting Bracket Kit .....SA161X57  
(Includes Panel Mount Nut)

Panel Mount Nut – Plastic.....R05X51-P  
Aluminum.....R05X51-A

Spring Cage & Knob .....CKR364Y

Spring Cage Kit (Tamperproof) .....CKR364T

**Repair Kits –**

**Standard Nitrile**

- Non-Relieving Diaphragm, Valve Assembly ..... RKR163Y
- Relieving Diaphragm, Valve Assembly..... RKR164Y

**Fluorocarbon**

- Non-Relieving Diaphragm, Valve Assembly .....RKR164KX64
- Relieving Diaphragm, Valve Assembly..... RKR164X64

**Specifications**

- Gauge Ports (2) ..... 1/8 Inch
- Port Threads ..... 1/8, 1/4 Inch
- Primary Pressure Rating ..... 2 to 125 PSIG (-15 to 8.5 bar)
- Supply Pressure .....300 PSIG Maximum (20.4 bar)
- Temperature Rating ..... 40°F to 125°F (4.4°C to 52°C)
- Weight – Brass Body ..... 0.5 lb. (0.23 kg) / Unit  
25 lb. (11.34 kg) / 48-Unit Master Pack
- Aluminum Body ..... 0.25 lb. (0.11 kg) / Unit  
15 lb. (6.80 kg) / 48-Unit Master Pack

**Materials of Construction**

- Adjusting Screw .....Steel
- Body – R364 .....Brass  
R374..... Aluminum
- Springs – Adjusting.....Steel  
Bottom .....Stainless Steel
- Spring Cage ..... Acetal
- Bottom Plug, Innervalue, Diaphragm Bottom .....Brass

**14E Filter / Regulator – Miniature**

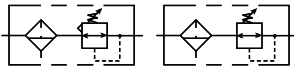

**Features**

- Excellent water removal efficiency.
- Unbalanced poppet standard.
- Solid control piston for extended life.
- Space saving package offers both filter and regulator features in one integral unit.
- Non-rising adjustment knob.
- Two full flow 1/8" gauge ports.
- High Flow: 1/8" – 16 SCFM<sup>§</sup>  
 1/4" – 18 SCFM<sup>§</sup>

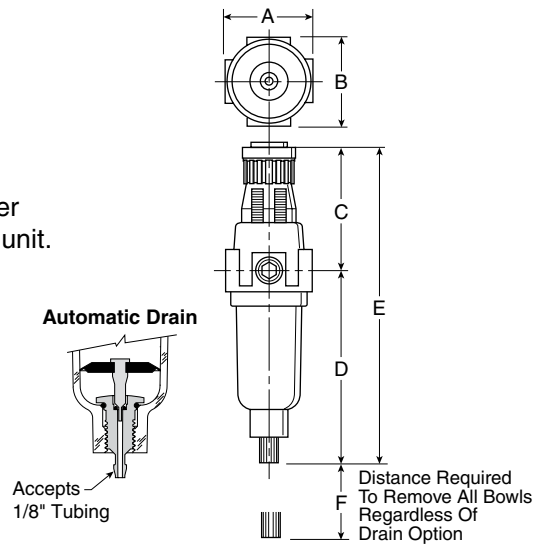

Port Size	NPT	
	Twist Drain	Automatic Pulse Drain
Poly Bowl <sup>‡</sup>		
1/8"	<b>14E01B13F*</b>	<b>14E05B13F*</b>
1/4"	<b>14E11B13F*</b>	<b>14E15B13F*</b>
Metal Bowl		
1/8"	<b>14E03B13F*</b>	<b>14E07B13F*</b>
1/4"	<b>14E13B13F*</b>	<b>14E17B13F*</b>

14E Filter / Regulator Dimensions		
<b>A</b> 1.62 (41)	<b>B</b> 1.58 (40)	<b>C</b> 2.42 (61)
<b>D</b> 3.79 (96)	<b>D<sup>†</sup></b> 3.64 (92)	<b>E</b> 6.21 (158)
<b>E<sup>†</sup></b> 6.06 (154)	<b>F</b> 1.60 (41)	

Standard part numbers shown bold. For other models refer to ordering information below.

<sup>‡</sup> For polycarbonate bowl see Caution on page 1.

<sup>§</sup> SCFM = Standard cubic feet per minute at 100 PSIG inlet, 90 PSIG no flow secondary setting and 10 PSIG pressure drop.

NOTE: 1.218 Dia. (31mm) hole required for panel mounting.

Inches (mm)  
<sup>†</sup> With Auto Drain

**Ordering Information**

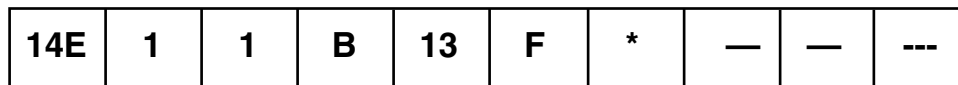

NOTE: BOLD OPTIONS ARE STANDARD.

Port Size
0 1/8 Inch
1 1/4 Inch

Elements
A 40 Micron
<b>B 5 Micron</b>
Z Adsorber

Relief
<b>F Relieving</b>
G Non-Relieving
H Low Temp. Relieving

Port Type
Blank NPT
1 BSPP
2 BSPT

Preset / Pressure Limited
Blank None
XXX* Preset Pressure
XXX* Pressure Limited

Bowl Options
Polycarbonate Bowl
<b>1 Twist Drain</b>
<b>5 Automatic Drain</b>
Metal Bowl
<b>3 Twist Drain</b>
<b>7 Automatic Drain</b>

Pressure Range	
Without Gauge	With Gauge
10 30 PSIG	15 30 PSIG
11 60 PSIG	16 60 PSIG
12 15 PSIG	17 15 PSIG
<b>13 125 PSIG</b>	18 125 PSIG

Engineering Level
* Will be Entered at Factory

Options
Blank No Options
L <sup>†</sup> Preset Non-Adjustable
P <sup>†</sup> Preset Adjustable
S <sup>†</sup> Pressure Limiter Max. Adjustable
T <sup>†</sup> Pressure Limiter Max.

\* Available Preset / Pressure Limited Range, 10 to 90 PSIG in 5 PSIG increments. For higher pressures, contact factory.

(Example: 065 = 65 PSIG)

**Spring Type by Preset / Limited Pressure:**

For Preset / Limited Pressure 10 to 25 use 30 PSI Spring  
 For Preset / Limited Pressure 26 to 50 use 60 PSI Spring  
 For Preset / Limited Pressure 51 to 90 use 125 PSI Spring

<sup>†</sup> Inlet Pressure is 100 PSIG. For other pressures, contact factory.

## Technical Information

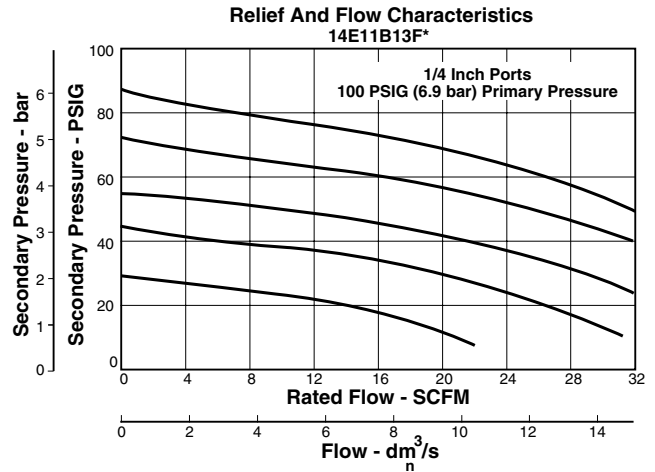
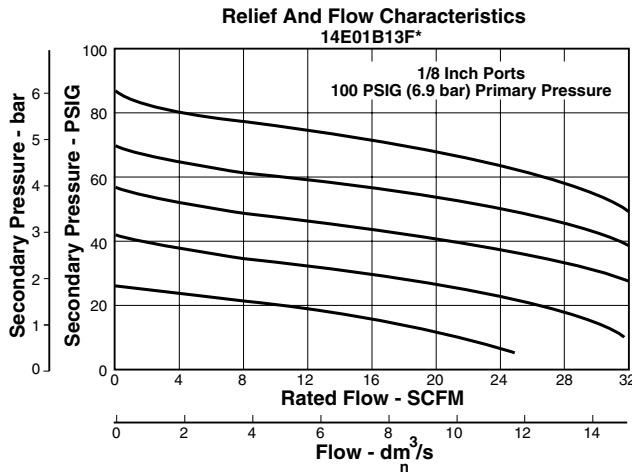

### CAUTION:

**REGULATOR PRESSURE ADJUSTMENT** – The working range of knob adjustment is designed to permit outlet pressures within their full range. Pressure adjustment beyond this range is also possible because the knob is not a limiting device. This is a common characteristic of most industrial regulators, and limiting devices may be obtained only by special design.

For best performance, regulated pressure should always be set by increasing the pressure up to the desired setting.

**⚠ WARNING**

**Product rupture can cause serious injury.  
Do not connect regulator to bottled gas.  
Do not exceed maximum primary pressure rating.**

## 14E Filter / Regulator Kits & Accessories

### Bowl Kits –

- Polycarbonate Bowl – Automatic Drain..... PS408P
- Twist Drain..... PS404P
- Metal Bowl – Automatic Drain..... PS451P
- Twist Drain..... PS447BP

- Filter Element Kits** – 40 Micron ..... PS401P
- 5 Micron ..... PS403P
- Adsorber..... PS452P

- Gauges** – 30 PSIG (0 to 2.1 bar) ..... K4515N18030
- 60 PSIG (0 to 4.1 bar) ..... K4515N18060
- 160 PSIG (0 to 11.0 bar) ..... K4515N18160

- Mounting Bracket Kit** (Includes Panel Mount Nut) ..... PS417BP

- Panel Mount Nut** ..... P78652

- Poppet Kits** – Unbalanced..... PS424BP
- Balanced..... PS425BP

- Service Kits** – Non-Relieving ..... PS422P
- Relieving ..... PS423P

- Springs** – 1- 15 PSIG Range (Yellow)..... P01176
- 1- 30 PSIG Range (Black) ..... P01175
- 1- 60 PSIG Range (White)..... P01174
- 2- 125 PSIG Range (Gold) ..... P01173

### Specifications

- Automatic Pulse Drain Tube Barb** ..... 1/8 Inch
- Bowl Capacity** ..... 1 Ounce
- Gauge Ports (2)** (Can be used for Full Flow)..... 1/8 Inch
- Port Threads** ..... 1/8, 1/4 Inch

### Pressure & Temperature Ratings –

- Polycarbonate Bowl  
0 to 150 PSIG (0 to 10.3 bar), 32°F to 125°F (0°C to 52°C)
- Metal Bowl  
0 to 250 PSIG (0 to 17.2 bar), 32°F to 175°F (0°C to 80°C)

### Secondary Pressure Ranges –

- Standard Pressure..... 2 to 125 PSIG (0 to 8.6 bar)
- Medium Pressure ..... 1 to 30 PSIG (0 to 2.1 bar)
- Medium Pressure ..... 1 to 60 PSIG (0 to 4.1 bar)
- Low Pressure..... 1 to 15 PSIG (0 to 1 bar)

- Weight** ..... 0.4 lb. (0.18 kg)

### Materials of Construction

- Adjusting Nut** ..... Brass
- Adjusting Stem & Spring** ..... Steel
- Body**..... Zinc
- Bonnet, Knob, Seat, Piston, Holder & Deflector** ..... Plastic
- Bowls Available** – Transparent ..... Polycarbonate
- Metal (Without Sight Gauge) ..... Zinc
- Drains** – Manual – Twist Type
  - Body & Stem ..... Plastic
  - Seals ..... Nitrile
- Automatic – Pulse Type
  - Piston & Seals ..... Nitrile
  - Stem, Seat, Adaptor & Washers ..... Aluminum
- Filter Elements** – 5 Micron (Standard) ..... Plastic
- 40 Micron (Optional) ..... Plastic
- Adsorber (Optional) ..... Activated Charcoal
- Seals** ..... Nitrile

## B548 Filter / Regulator – Miniature

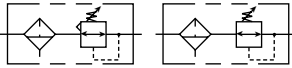

### Features

- Excellent Water Removal Efficiency
- Unbalanced Poppet Standard
- Solid Control Piston for Extended Life
- Space Saving Package Offers Both Filter and Regulator Features in One Integral Unit
- Non-rising Adjustment Knob
- High Flow: 12 SCFM<sup>§</sup>

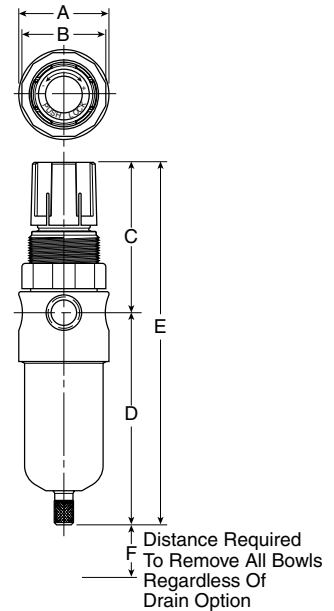

<b>Port Size</b>	<b>NPT</b>
	<b>Manual Twist Drain</b>
Poly Bowl <sup>‡</sup>	
1/8"	<b>B548-01AHC</b>
1/4"	<b>B548-02AHC</b>
Metal Bowl without Sight Gauge	
1/8"	<b>B548-01DHC</b>
1/4"	<b>B548-02DHC</b>

Standard part numbers shown bold. For other models refer to ordering information below.

<sup>‡</sup> For polycarbonate bowl see Caution on page 1.

<sup>§</sup> SCFM = Standard cubic feet per minute at 100 PSIG inlet, 75 PSIG no flow secondary setting and 25% pressure drop.

NOTE: 1.218 Dia. (31mm) hole required for panel mounting.

<b>B548 Filter / Regulator Dimensions</b>		
<b>A</b>	<b>B</b>	<b>C</b>
1.55 (39.2)	4.44 (36.5)	2.58 (65.6)
<b>D</b>	<b>E</b>	<b>F</b>
6.23 (158.2)	3.81 (96.7)	0.86 (21.9)

Inches (mm)  
<sup>†</sup> With Auto Drain

## Ordering Information

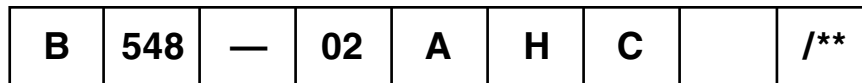

<b>Port Threads</b> — NPT G BSPP	<b>Port Size</b> 01 1/8 Inch 02 1/4 Inch	<b>Bowl</b> <b>A</b> Polycarbonate Bowl D Metal without Sight Gauge	<b>Elements</b> G 5 Micron <b>H</b> 20 Micron	<b>Reduced Pressure Range</b> A 0-25 PSIG B 0-60 PSIG <b>C</b> 0-125 PSIG	<b>Options</b> G Gauge K Non-Relieving P Panel Mount (Plastic) S Automatic Pulse Drain T Tamperproof X64 Fluorocarbon O-rings & Diaphragm X33* Polyurethane Bowl	<b>Engineering Change Designator</b> Will be entered at factory.
--	--	---	---	--	---	---

\* Add .65" to overall length.

NOTE: BOLD OPTIONS ARE STANDARD.



Technical Information

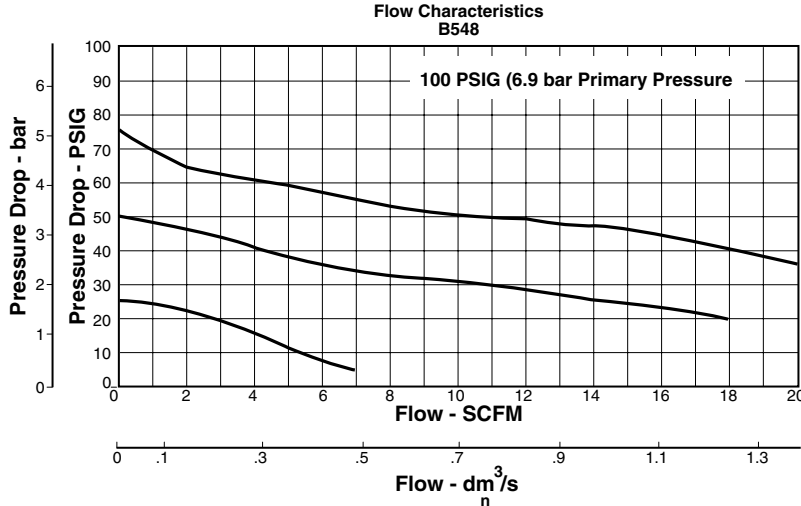

**CAUTION:**

**REGULATOR PRESSURE ADJUSTMENT** – The working range of knob adjustment is designed to permit outlet pressures within their full range. Pressure adjustment beyond this range is also possible because the knob is not a limiting device. This is a common characteristic of most industrial regulators, and limiting devices may be obtained only by special design.

For best performance, regulated pressure should always be set by increasing the pressure up to the desired setting.

**⚠ WARNING**

**Product rupture can cause serious injury.  
Do not connect regulator to bottled gas.  
Do not exceed maximum primary pressure rating.**

**B548 Filter / Regulator Kits & Accessories**

- Bowl Kits –**
- Zinc (D) .....BK505Y
- Zinc with Automatic Pulse Drain (D)..... BK505SY
- Polycarbonate (A) ..... BK504Y
- Polycarbonate with Automatic Pulse Drain (A)..... BK504SY
- Cage Kits (All) .....CKR364Y**
- Drain Kits –**
- Automatic Pulse Drain  
(Maximum Pressure = 175 PSIG)..... RK504SY
- Filter Element Kits –**
- 20 Micron (All)..... EK504Y
- 5 Micron (All)..... EK504VY
- Gauges –**
- 1-1/2" Dial Size, 1/8" Back Connection  
0 to 60 PSIG (0 to 400 kPa)..... K4515N18060
- 1-1/2" Dial Size, 1/8" Back Connection  
0 to 160 PSIG (0 to 1100 kPa) .....K4515N18160
- Mounting Bracket Kit (Includes Plastic Panel Nut) .....SA161X57**
- Panel Mount Nut –**
- Plastic.....R05X51-P
- Aluminum .....R05X51-A
- Repair Kits –**
- Non-Relieving Diaphragm, Valve Assembly (All) .....RK548Y
- Relieving Diaphragm, Valve Assembly (All) .....RK549Y

**Specifications**

- Bowl Capacity** ..... 1 Ounce
- Gauge Ports (2)** ..... 1/8 Inch

- Maximum Pressure –**
- Zinc Bowl (D) ..... 0 to 300 PSIG
- Polycarbonate Bowl (A) ..... 0 to 150 PSIG
- Port Threads** ..... 1/4 Inch
- Reduced Pressure Range –**
- 0 to 25 PSIG ..... (0 to 1.7 bar) (A)
- 0 to 60 PSIG .....(0 to 4.1 bar) (B)
- 2 to 125 PSIG .....(0.15 to 8.5 bar) (C)
- Temperature Rating** ..... 40°F to 125°F (4.4°C to 52°C)
- Weight –**
- Zinc Bowl (D) ..... 0.6 lb. (0.27 kg) / Unit  
12 lb. (5.44 kg) / 24-Unit Master Pack
- Polycarbonate Bowl (A) .....0.3 lb. (0.14 kg) / Unit  
6 lb. (2.72 kg) / 24-Unit Master Pack

**Materials of Construction**

- Adjusting Knob** ..... Acetal
- Body** ..... Aluminum
- Bowls –**
- Polycarbonate (A) ..... Polycarbonate
- Metal (D) ..... Zinc  
Zinc with Automatic Pulse Drain
- Elastomers** ..... Buna N
- Filter Element** ..... Sintered Polypropylene
- Filter Retainer, Vane Plate** ..... Acetal
- Innervolve, Diaphragm, Button, Drain** ..... Brass

**04L Mist Lubricators – Miniature**



**Features**

- Proportional oil delivery over a wide range of air flows.
- Precision needle valve assures repeatable oil delivery and provides simple adjustment of delivery rate.
- Ideal for low and high flow applications with changing air flow.
- Transparent sight dome for 360° visibility.
- High Flow: 1/8" – 20 SCFM§  
 1/4" – 20 SCFM§

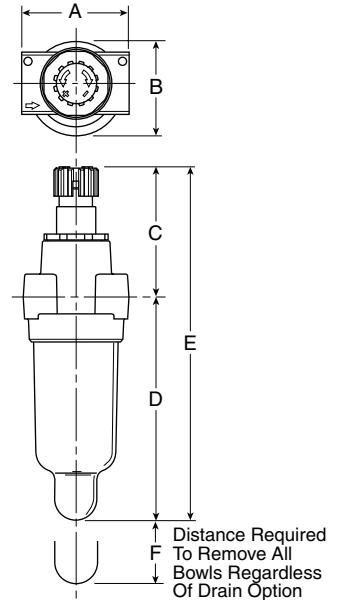

Port Size	NPT	
	Twist Drain	No Drain
Poly Bowl †		
1/8"	—	<b>04L00G*</b>
1/4"	—	<b>04L10G*</b>
Metal Bowl without Sight Gauge		
1/8"	<b>04L03G*</b>	—
1/4"	<b>04L13G*</b>	—

04L Lubricator Dimensions		
<b>A</b> 1.73 (44)	<b>B</b> 1.56 (40)	<b>C</b> 2.16 (55)
<b>D</b> 3.64 (92)	<b>D†</b> 3.78 (96)	<b>E</b> 5.80 (147)
<b>E†</b> 5.94 (151)	<b>F</b> 1.60 (41)	

Standard part numbers shown bold. For other models refer to ordering information below.

† For polycarbonate bowl see Caution on page 1.

§ SCFM = Standard cubic feet per minute at 90 PSIG inlet and 5 PSIG pressure drop.

Inches (mm)  
 † With Twist Drain.

**Ordering Information**

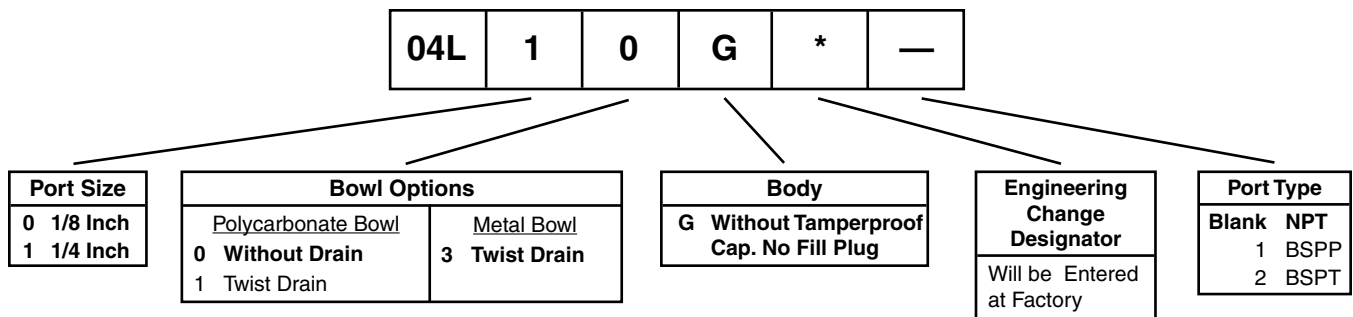

NOTE: BOLD OPTIONS ARE STANDARD.

Technical Information

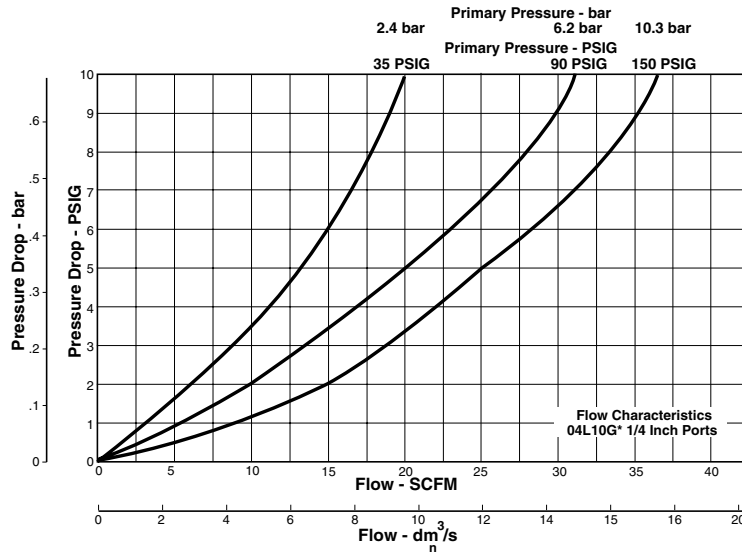
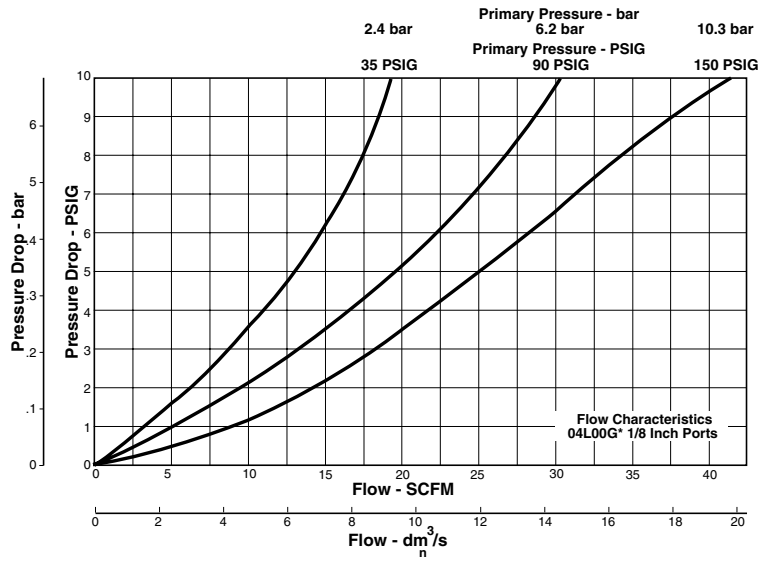

04L Mist Lubricator Kits & Accessories

Bowl Kits –

- Poly Bowl – No Drain ..... PS421P
- Twist Drain ..... PS420P
- Metal Bowl – Twist Drain (No Sight Gauge) ..... PS447BP

Mounting Bracket Kit ..... PS419

- Oil – 1 Gal. .... F442002
- 12 Quart Case ..... F442003
- 4 Gallon Case ..... F442005

Specifications

- Bowl Capacity ..... 1 Ounce
- Minimum Flow for Lubrication ..... 0.5 SCFM at 100 PSIG
- Port Threads ..... 1/8, 1/4 Inch
- Pressure & Temperature Ratings –
  - Polycarbonate Bowl ..... 0 to 150 PSIG (0 to 10.3 bar)  
32°F to 125°F (0°C to 52°C)
  - Metal Bowl ..... 0 to 250 PSIG (0 to 17.2 bar)  
32°F to 175°F (0°C to 80°C)

Suggested Lubricant – ..... F442 Oil

Petroleum based oil of 100 to 200 SSU viscosity at 100°F and an aniline point greater than 200°F (DO NOT USE OILS WITH ADDITIVES, COMPOUNDED OILS CONTAINING SOLVENTS, GRAPHITE, DETERGENTS, OR SYNTHETIC OILS.)

Weight ..... 0.4 lb. (0.18 kg)

Materials of Construction

- Body ..... Zinc
- Bowls – Transparent ..... Polycarbonate
- Metal (Without Sight Gauge) ..... Zinc
- Drains – Twist – Body & Nut ..... Plastic
- Seals ..... Nitrile
- Sight Dome ..... Polycarbonate

## L508 Mist Lubricators – Miniature

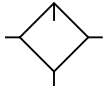

### Features

- Proportional Oil Delivery Over a Wide Range of Air Flows
- Precision Needle Valve Assures Repeatable Oil Delivery and Provides Simple Adjustment of Delivery Rate
- Ideal for Low and High Flow Applications with Changing Air Flow
- Polycarbonate Sight Dome for 360° Visibility
- High Flow: 1/8" – 20 SCFM<sup>§</sup>  
 1/4" – 20 SCFM<sup>§</sup>

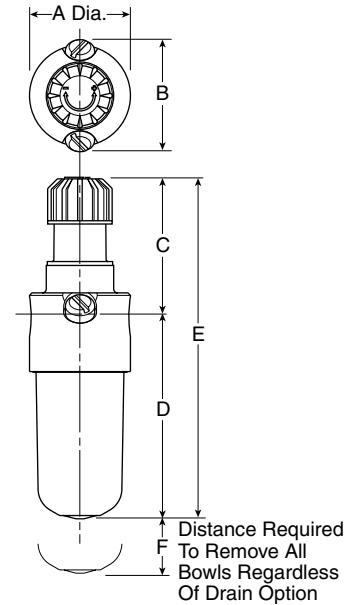

Port Size	NPT	
	Twist Drain	No Drain
Poly Bowl <sup>†</sup>		
1/8"	<b>L508-01A</b>	<b>L508-01AX9</b>
1/4"	<b>L508-02A</b>	<b>L508-02AX9</b>
Metal Bowl without Sight Gauge		
1/8"	<b>L508-01D</b>	<b>L508-01DX9</b>
1/4"	<b>L508-02D</b>	<b>L508-02DX9</b>

L508 Lubricator Dimensions		
<b>A</b>	<b>B</b>	<b>C</b>
1.55 (39.2)	1.74 (44)	2.21 (56)
<b>D</b>	<b>D<sup>†</sup></b>	<b>E</b>
3.10 (70.7)	3.68 (93.5)	5.21 (132)
<b>E<sup>†</sup></b>	<b>F</b>	
5.79 (147)	1.70 (43)	

Standard part numbers shown bold. For other models refer to ordering information below.

<sup>†</sup> For polycarbonate bowl see Caution on page 1.

<sup>§</sup> SCFM = Standard cubic feet per minute at 90 PSIG inlet and 5 PSIG pressure drop.

Inches (mm)

<sup>†</sup> With Twist Drain.

## Ordering Information

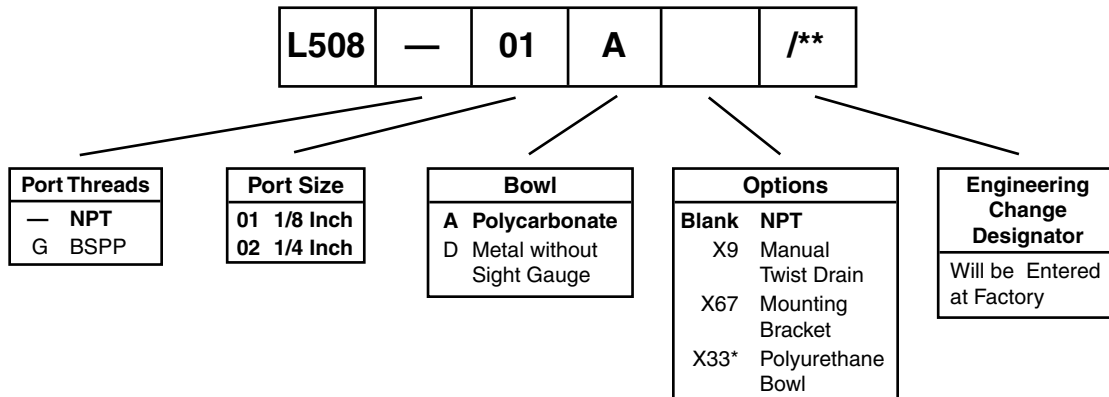

\* Add .65" to overall length.

NOTE: BOLD OPTIONS ARE STANDARD.

Technical Information

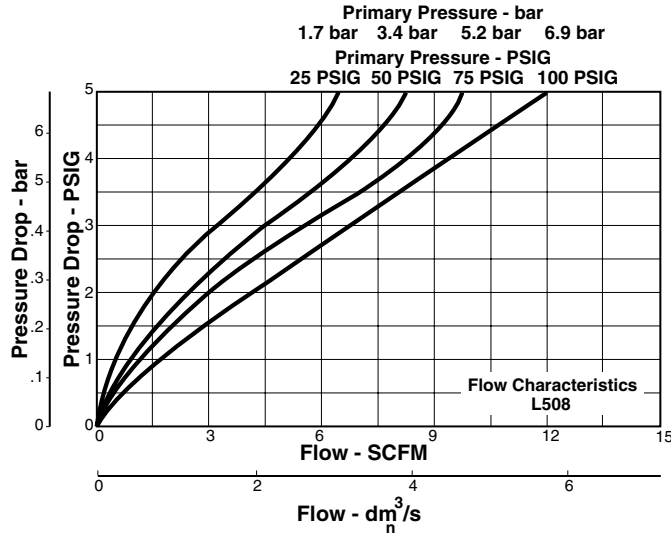

L508 Mist Lubricator Kits & Accessories

Bowl Kits –

- Polycarbonate Bowl –
  - No Drain .....BK508Y
  - Manual Twist Drain .....BK504Y
- Metal Bowl –
  - No Drain .....BK509Y
  - Manual Twist Drain (No Sight Gauge).....BK505Y

Mounting Bracket Kit ..... Must Be Ordered with Lubricator

Oil –

- 1 Gal.....F442002
- 12 Quart Case.....F442003
- 4 Gallon Case .....F442005

Specifications

- Bowl Capacity..... 1 Ounce
- Minimum Flow for Lubrication ..... 0.5 SCFM at 100 PSIG
- Port Threads..... 1/8, 1/4 Inch
- Pressure & Temperature Ratings –
  - Polycarbonate Bowl – ..... 0 to 150 PSIG (0 to 10.3 bar)  
32°F to 125°F (0°C to 52°C)
  - Metal Bowl –.....0 to 300 PSIG (0 to 20.4 bar)  
40°F to 150°F (4°C to 65.6°C)

Suggested Lubricant – ..... F442 Oil

Petroleum based oil of 100 to 200 SSU viscosity at 100°F and an aniline point greater than 200°F

(DO NOT USE OILS WITH ADDITIVES, COMPOUNDED OILS CONTAINING SOLVENTS, GRAPHITE, DETERGENTS, OR SYNTHETIC OILS.)

Weight ..... 0.4 lb. (0.18 kg)

Materials of Construction

- Body ..... Aluminum
- Bowls –
  - Polycarbonate ..... Polycarbonate
  - Metal (Without Sight Gauge) ..... Zinc
- Drains –
  - Manual Twist ..... Brass
- Seals ..... Nitrile
- Sight Dome ..... Polyurethane

**Close Nippled Combinations – 14 Miniature Series**

- See individual component pages for details.

**Two-Unit Combo**

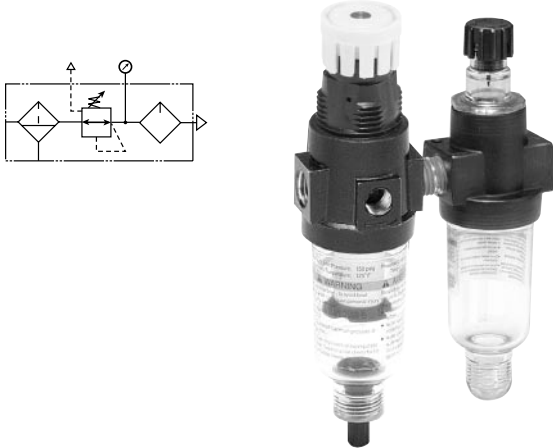

Series	Port	Model Numbers
14G	1/8"	14G01B13F0G*
	1/4"	14G11B13F0G*

For other models, refer to ordering information on next page.

A	B	C	D	E	F
3.75 (95)	3.79 (96)	2.42 (61)	2.04 (52)	6.21 (158)	0.79 (20)

Inches (mm)  
Note: All dimensions nominal.

**Three-Unit Combo**

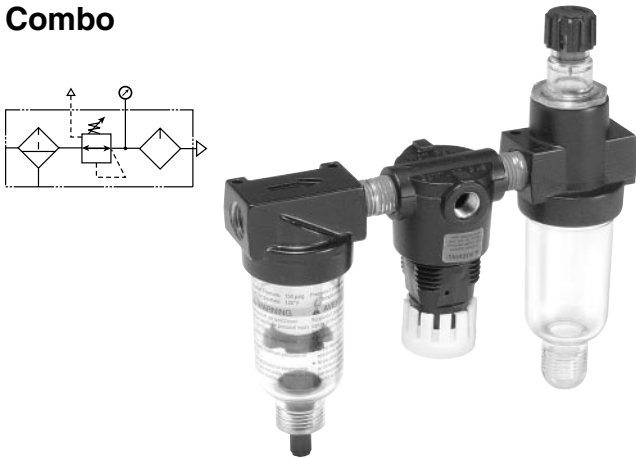

Series	Port	Model Numbers
14A	1/8"	14A01B13F0G*
	1/4"	14A11B13F0G*

For other models, refer to ordering information on next page.

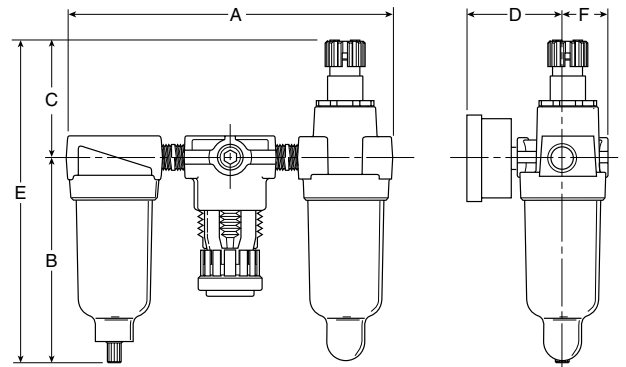

A	B	C	D	E	F
5.77 (147)	3.82 (97)	2.16 (55)	2.04 (52)	5.98 (152)	0.79 (20)

Inches (mm)  
Note: All dimensions nominal.

- Regulator can be mounted with knob in up or down position.

**Close Nipped Combinations – 14 Miniature Series**

**Ordering Information**

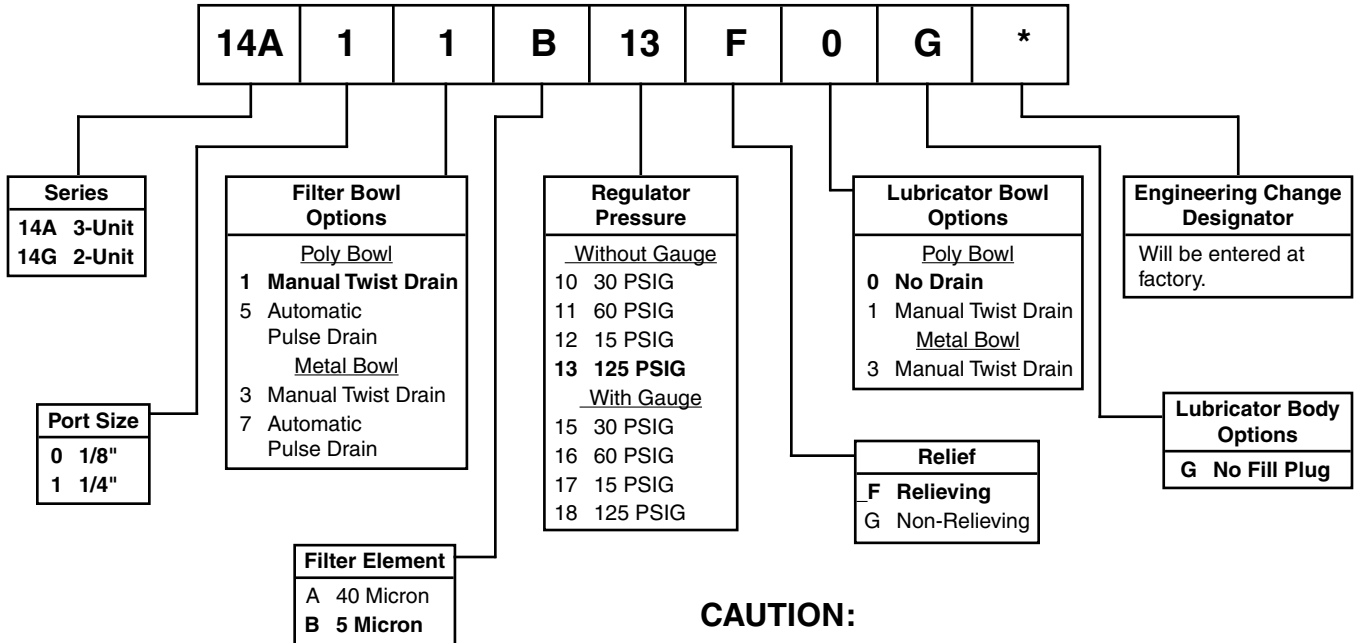

**CAUTION:**

**REGULATOR PRESSURE ADJUSTMENT** – The working range of knob adjustment is designed to permit outlet pressures within their full range. Pressure adjustment beyond this range is also possible because the knob is not a limiting device. This is a common characteristic of most industrial regulators, and limiting devices may be obtained only by special design.

NOTE: BOLD OPTIONS ARE STANDARD.

**Mounting Bracket Kits**

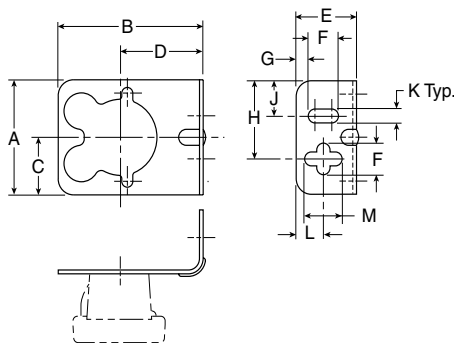

**PS417BP**  
 (Includes Panel Mount Nut)

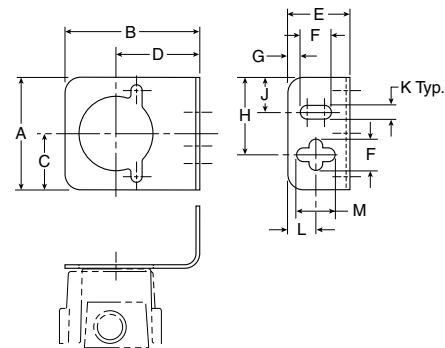

**PS419**

**Dimensions**

A	B	C	D	E	F	G	H	J	K	L	M	Kit
1.80 (46)	2.37 (60)	0.90 (23)	1.35 (34)	1.00 (25)	0.50 (13)	0.20 (5)	1.24 (31)	0.56 (14)	0.22 (6)	0.45 (11)	0.62 (16)	<b>PS417BP</b> (14F, 10F, 14R, 14E)
1.80 (46)	2.17 (55)	0.90 (23)	1.35 (34)	1.00 (25)	0.50 (13)	0.20 (5)	1.24 (31)	0.56 (14)	0.22 (6)	0.45 (11)	0.62 (16)	<b>PS419</b> (04L)

Inches (mm)  
 Note: All dimensions nominal.

**Close Nippled Combinations – C528 Miniature Series**

- See individual component pages for details.

**Two-Unit Combo**

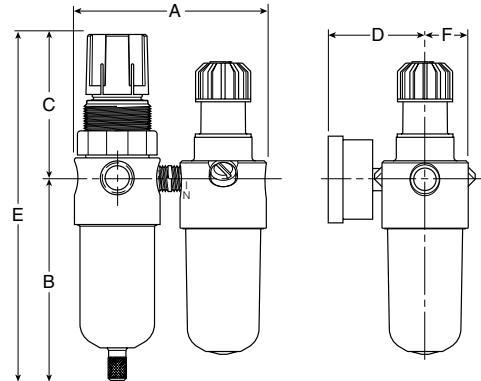
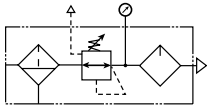

Series	Port	Model Numbers
C528BL	1/8", 1/4"	C528-**-BLAHCA
	1/8", 1/4"	C528-**-BLDHCD

A	B	C	D	E	F
3.50 (89)	3.50 (89)	2.38 (60)	1.98 (50)	5.88 (149)	0.77 (20)

\*\* Port Size 01 = 1/8", 02 = 1/4".  
For other models, refer to ordering information on next page.

Inches (mm)  
Note: All dimensions nominal.

**Three-Unit Combo**

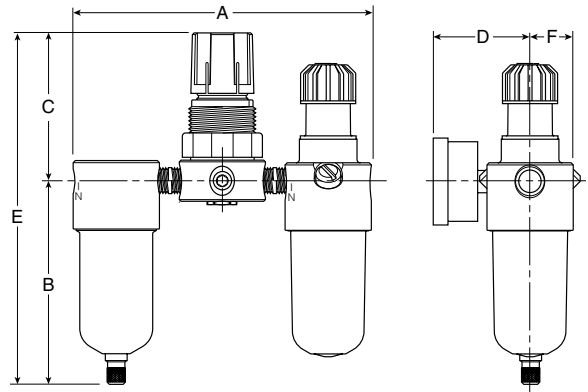
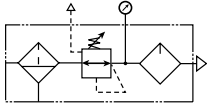

Series	Port	Model Numbers
C528FRL	1/8", 1/4"	C528-**-FRLAHCA
	1/8", 1/4"	C528-**-FRLDHCD

A	B	C	D	E	F
5.13 (130)	3.50 (89)	1.63 (41)	1.98 (50)	5.13 (130)	0.77 (20)

\*\* Port Size 01 = 1/8", 02 = 1/4".  
For other models, refer to ordering information on next page.

Inches (mm)  
Note: All dimensions nominal.



**Close Nipped Combinations – C528 Miniature Series**

**Ordering Information**

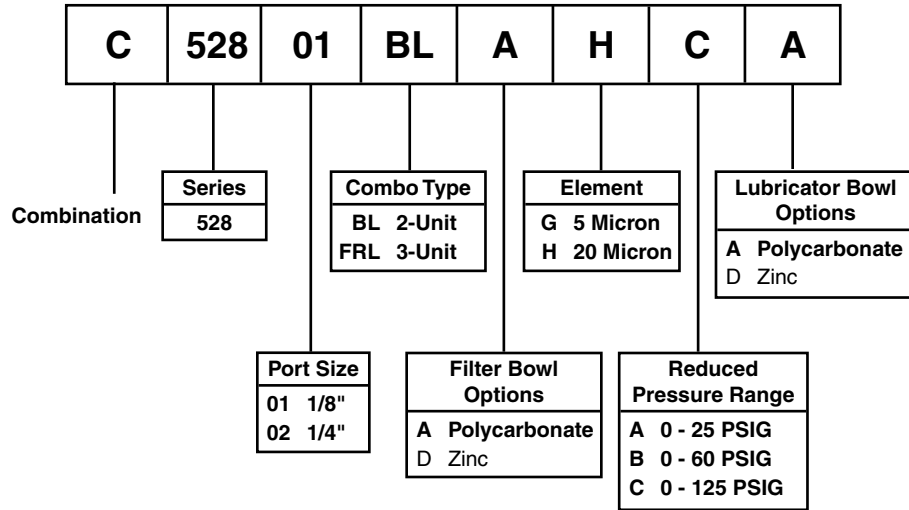

**NOTE: BOLD OPTIONS ARE STANDARD.**

**CAUTION:**

**REGULATOR PRESSURE ADJUSTMENT** – The working range of knob adjustment is designed to permit outlet pressures within their full range. Pressure adjustment beyond this range is also possible because the knob is not a limiting device. This is a common characteristic of most industrial regulators, and limiting devices may be obtained only by special design.

**Mounting Bracket Kit**

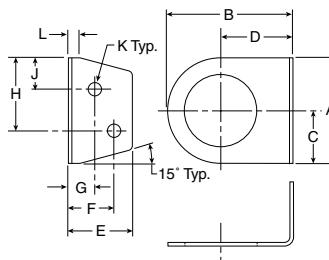

**SA 161 x 57**  
 (Comes with R05X51-P Panel Nut)

**Dimensions**

A	B	C	D	E	F	G	H	J	K	L	M	Kit
1.75 (44)	2.06 (53)	0.88 (22)	1.19 (30)	1.06 (27)	0.75 (19)	0.44 (11)	1.22 (31)	0.53 (13)	0.22 (6)	0.19 (5)	— —	<b>161 x 57</b>

Inches (mm)  
 Note: All dimensions nominal.

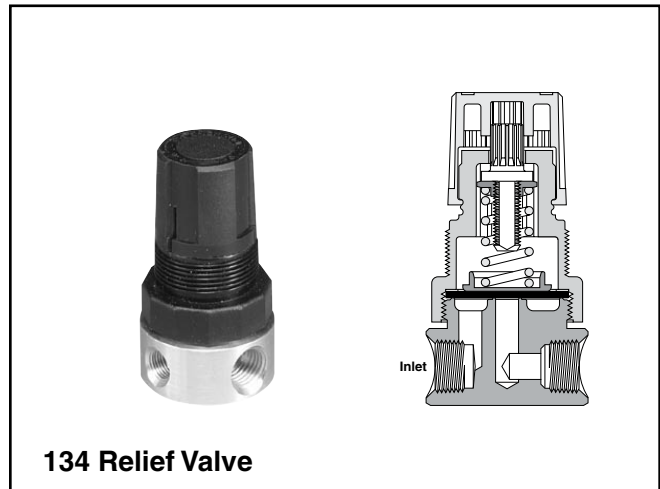
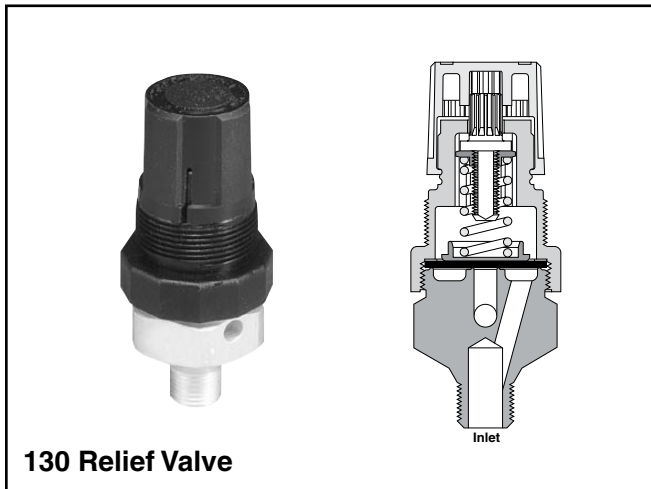

**Features**

- Compact, sensitive diaphragm-type relief valve.
- Push-pull, locking knob.
- Knob and top work the same as a miniature regulator.
- 130 has lightweight aluminum construction.
- 134 has a brass body, captured exhaust and is an inline type with 3 inlet ports and 1 outlet port.

**Applications**

- Designed to protect against excessive pressure buildup in a pneumatic circuit or system.
- For use where gradual proportional relief is required.

**Operation**

- Turn relief valve knob clockwise for maximum pressure.
- Set pressure going into relief valve at desired pressure.
- Turn relief valve knob counter-clockwise until exhaust starts to bleed.
- Turn relief valve knob clockwise until exhaust stops bleeding. Push to lock knob.

**Ordering Information**

Relief Valve	Spring Range			
	0-15 PSIG	0-25 PSIG	0-50 PSIG	0-100 PSIG
130	130-02AA	130-02A	130-02B	130-02C
	130-02AAP*	130-02AP*	130-02BP*	130-02CP*
134	134-02AA	134-02A	134-02B	134-02C
	134-02AAP*	134-02AP*	134-02BP*	134-02CP*

\* Panel mount nut included.

**Dimensions**

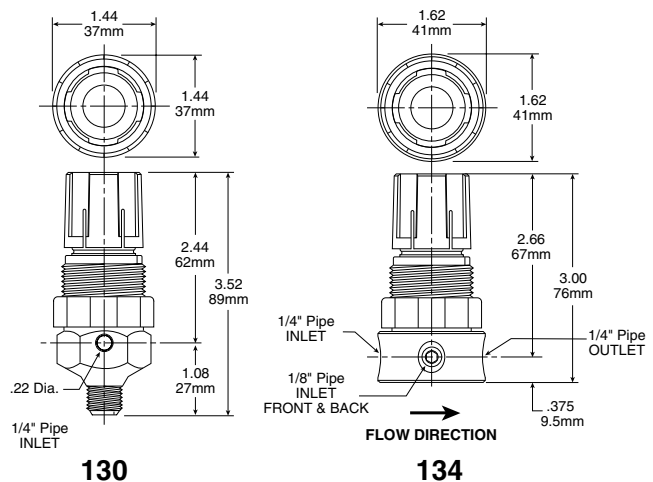

**Relief Valve Kits**

- Bonnet Assembly Kit ..... CKR364Y
- Panel Mount Nut ..... R05X51-P

**Specifications**

- Relief Range ..... 0 to 100 PSIG (0 to 6.9 bar)
- Maximum Inlet Pressure ..... 300 PSIG (20.7 bar)
- Operating Temperature ..... 40°F to 125°F (4°C to 52°C)
- Port Threads –
  - 130 ..... 1/4" Pipe Male Only
  - 134 ..... Inlet Port – Two 1/8" & One 1/4" Pipe  
Outlet Port – 1/4" Pipe

**Materials of Construction**

- Adjusting Knob ..... Polypropylene
- Adjusting Screw ..... Zinc-plated Steel
- Body ..... Aluminum (130); Brass (134)
- Diaphragm / Disc ..... Buna-N
- Nut ..... Chromated Steel
- Spring Cage ..... Acetal
- Spring ..... Zinc-plated Steel

**Notes**

---

# Safety Guide For Selecting And Using Pneumatic Division Products And Related Accessories

## WARNING:

**FAILURE OR IMPROPER SELECTION OR IMPROPER USE OF PNEUMATIC DIVISION PRODUCTS, ASSEMBLIES OR RELATED ITEMS (“PRODUCTS”) CAN CAUSE DEATH, PERSONAL INJURY, AND PROPERTY DAMAGE. POSSIBLE CONSEQUENCES OF FAILURE OR IMPROPER SELECTION OR IMPROPER USE OF THESE PRODUCTS INCLUDE BUT ARE NOT LIMITED TO:**

- Unintended or mistimed cycling or motion of machine members or failure to cycle
- Work pieces or component parts being thrown off at high speeds.
- Failure of a device to function properly for example, failure to clamp or unclamp an associated item or device.
- Explosion
- Suddenly moving or falling objects.
- Release of toxic or otherwise injurious liquids or gasses.

Before selecting or using any of these Products, it is important that you read and follow the instructions below.

## 1. GENERAL INSTRUCTIONS

- 1.1. Scope:** This safety guide is designed to cover general guidelines on the installation, use, and maintenance of Pneumatic Division Valves, FRLs (Filters pressure Regulators and Lubricators), Vacuum products and related accessory components.
- 1.2. Fail-Safe:** Valves, FRLs, Vacuum products and their related components can and do fail without warning for many reasons. Design all systems and equipment in a fail-safe mode, so that failure of associated valves, FRLs or Vacuum products will not endanger persons or property.
- 1.3. Distribution:** Provide a copy of this safety guide to each person that is responsible for selection, installation, or use of Valves, FRLs or Vacuum products. Do not select, or use Watts valves, FRLs or vacuum products without thoroughly reading and understanding this safety guide as well as the specific Watts publications for the products considered or selected.
- 1.4. User Responsibility:** Due to the wide variety of operating conditions and applications for valves, FRLs, and vacuum products Watts and its distributors do not represent or warrant that any particular valve, FRL or vacuum product is suitable for any specific end use system. This safety guide does not analyze all technical parameters that must be considered in selecting a product. The user, through its own analysis and testing, is solely responsible for:
  - Making the final selection of the appropriate valve, FRL, Vacuum component, or accessory.
  - Assuring that all user’s performance, endurance, maintenance, safety, and warning requirements are met and that the application presents no health or safety hazards.
  - Complying with all existing warning labels and / or providing all appropriate health and safety warnings on the equipment on which the valves, FRLs or Vacuum products are used; and,
  - Assuring compliance with all applicable government and industry standards.
- 1.5. Safety Devices:** Safety devices should not be removed, or defeated.
- 1.6. Warning Labels:** Warning labels should not be removed, painted over or otherwise obscured.
- 1.7. Additional Questions:** Call the appropriate Watts technical service department if you have any questions or require any additional information. See the Watts publication for the product being considered or used, or call 269-629-5000, or go to [www.wattsfluidair.com](http://www.wattsfluidair.com), for telephone numbers of the appropriate technical service department.

## 2. PRODUCT SELECTION INSTRUCTIONS

- 2.1. Flow Rate:** The flow rate requirements of a system are frequently the primary consideration when designing any pneumatic system. System components need to be able to provide adequate flow and pressure for the desired application.
- 2.2. Pressure Rating:** Never exceed the rated pressure of a product. Consult product labeling, Pneumatic Division catalogs or the instruction sheets supplied for maximum pressure ratings.
- 2.3. Temperature Rating:** Never exceed the temperature rating of a product. Excessive heat can shorten the life expectancy of a product and result in complete product failure.
- 2.4. Environment:** Many environmental conditions can affect the integrity and suitability of a product for a given application. Pneumatic Division products are designed for use in general purpose industrial applications. If these products are to be used in unusual circumstances such as direct sunlight and/or corrosive or caustic environments, such use can shorten the useful life and lead to premature failure of a product.
- 2.5. Lubrication and Compressor Carryover:** Some modern synthetic oils can and will attack nitrile seals. If there is any possibility of synthetic oils or greases migrating into the pneumatic components check for compatibility with the seal materials used. Consult the factory or product literature for materials of construction.
- 2.6. Polycarbonate Bowls and Sight Glasses:** To avoid potential polycarbonate bowl failures:
  - Do not locate polycarbonate bowls or sight glasses in areas where they could be subject to direct sunlight, impact blow, or temperatures outside of the rated range.
  - Do not expose or clean polycarbonate bowls with detergents, chlorinated hydro-carbons, ketones, esters or certain alcohols.
  - Do not use polycarbonate bowls or sight glasses in air systems where compressors are lubricated with fire resistant fluids such as phosphate ester and di-ester lubricants.

## Safety Guide

---

- 2.7. Chemical Compatibility:** For more information on plastic component chemical compatibility see Pneumatic Division technical bulletins Tec-3, Tec-4, and Tec-5
- 2.8. Product Rupture:** Product rupture can cause death, serious personal injury, and property damage.
- Do not connect pressure regulators or other Pneumatic Division products to bottled gas cylinders.
  - Do not exceed the maximum primary pressure rating of any pressure regulator or any system component.
  - Consult product labeling or product literature for pressure rating limitations.

### 3. PRODUCT ASSEMBLY AND INSTALLATION INSTRUCTIONS

- 3.1. Component Inspection:** Prior to assembly or installation a careful examination of the valves, FRLs or vacuum products must be performed. All components must be checked for correct style, size, and catalog number. DO NOT use any component that displays any signs of nonconformance.
- 3.2. Installation Instructions:** Watts published Installation Instructions must be followed for installation of Watts valves, FRLs and vacuum components. These instructions are provided with every Watts valve or FRL sold, or by calling 269-629-5000, or at [www.wattsfluidair.com](http://www.wattsfluidair.com).
- 3.3. Air Supply:** The air supply or control medium supplied to Valves, FRLs and Vacuum components must be moisture-free if ambient temperature can drop below freezing

### 4. VALVE AND FRL MAINTENANCE AND REPLACEMENT INSTRUCTIONS

- 4.1. Maintenance:** Even with proper selection and installation, valve, FRL and vacuum products service life may be significantly reduced without a continuing maintenance program. The severity of the application, risk potential from a component failure, and experience with any known failures in the application or in similar applications should determine the frequency of inspections and the servicing or replacement of Pneumatic Division products so that products are replaced before any failure occurs. A maintenance program must be established and followed by the user and, at minimum, must include instructions 4.2 through 4.10.
- 4.2. Installation and Service Instructions:** Before attempting to service or replace any worn or damaged parts consult the appropriate Service Bulletin for the valve or FRL in question for the appropriate practices to service the unit in question. These Service and Installation Instructions are provided with every Watts valve and FRL sold, or are available by calling 269-629-5000, or by accessing the Watts web site at [www.wattsfluidair.com](http://www.wattsfluidair.com).
- 4.3. Lockout / Tagout Procedures:** Be sure to follow all required lockout and tagout procedures when servicing equipment. For more information see: OSHA Standard – 29 CFR, Part 1910.147, Appendix A, The Control of Hazardous Energy – (Lockout / Tagout)
- 4.4. Visual Inspection:** Any of the following conditions requires immediate system shut down and replacement of worn or damaged components:
- Air leakage: Look and listen to see if there are any signs of visual damage to any of the components in the system. Leakage is an indication of worn or damaged components.
  - Damaged or degraded components: Look to see if there are any visible signs of wear or component degradation.
  - Kinked, crushed, or damaged hoses. Kinked hoses can result in restricted air flow and lead to unpredictable system behavior.
  - Any observed improper system or component function: Immediately shut down the system and correct malfunction.
  - Excessive dirt build-up: Dirt and clutter can mask potentially hazardous situations.

**Caution: Leak detection solutions should be rinsed off after use.**

- 4.5. Routine Maintenance Issues:**
- Remove excessive dirt, grime and clutter from work areas.
  - Make sure all required guards and shields are in place.
- 4.6. Functional Test:** Before initiating automatic operation, operate the system manually to make sure all required functions operate properly and safely.
- 4.7. Service or Replacement Intervals:** It is the user's responsibility to establish appropriate service intervals. Valves, FRLs and vacuum products contain components that age, harden, wear, and otherwise deteriorate over time. Environmental conditions can significantly accelerate this process. Valves, FRLs and vacuum components need to be serviced or replaced on routine intervals. Service intervals need to be established based on:
- Previous performance experiences.
  - Government and / or industrial standards.
  - When failures could result in unacceptable down time, equipment damage or personal injury risk.
- 4.8. Servicing or Replacing of any Worn or Damaged Parts:** To avoid unpredictable system behavior that can cause death, personal injury and property damage:
- Follow all government, state and local safety and servicing practices prior to service including but not limited to all OSHA Lockout Tagout procedures (OSHA Standard – 29 CFR, Part 1910.147, Appendix A, The Control of Hazardous Energy – Lockout / Tagout).
  - Disconnect electrical supply (when necessary) before installation, servicing, or conversion.
  - Disconnect air supply and depressurize all air lines connected to system and Pneumatic Division products before installation, service, or conversion.
  - Installation, servicing, and / or conversion of these products must be performed by knowledgeable personnel who understand how pneumatic products are to be applied.
  - After installation, servicing, or conversions air and electrical supplies (when necessary) should be connected and the product tested for proper function and leakage. If audible leakage is present, or if the product does not operate properly, do not put product or system into use.
  - Warnings and specifications on the product should not be covered or painted over. If masking is not possible, contact your local representative for replacement labels.
- 4.9. Putting Serviced System Back into Operation:** Follow the guidelines above and all relevant Installation and Maintenance Instructions supplied with the valve FRL or vacuum component to insure proper function of the system.

## Offer of Sale

The items described in this document and other documents or descriptions provided by Parker Hannifin Corporation, its subsidiaries and its authorized distributors, are hereby offered for sale at prices to be established by Parker Hannifin Corporation, its subsidiaries and its authorized distributors. This offer and its acceptance by any customer ("Buyer") shall be governed by all of the following Terms and Conditions. Buyer's order for any such item, when communicated to Parker Hannifin Corporation, its subsidiaries or an authorized distributor ("Seller") verbally or in writing, shall constitute acceptance of this offer.

**1. Terms and Conditions of Sale:** All descriptions, quotations, proposals, offers, acknowledgments, acceptances and sales of Seller's products are subject to and shall be governed exclusively by the terms and conditions stated herein. Buyer's acceptance of any offer to sell is limited to these terms and conditions. Any terms or conditions in addition to, or inconsistent with those stated herein, proposed by Buyer in any acceptance of an offer by Seller, are hereby objected to. No such additional, different or inconsistent terms and conditions shall become part of the contract between Buyer and Seller unless expressly accepted in writing by Seller. Seller's acceptance of any offer to purchase by Buyer is expressly conditional upon Buyer's assent to all the terms and conditions stated herein, including any terms in addition to, or inconsistent with those contained in Buyer's offer. Acceptance of Seller's products shall in all events constitute such assent.

**2. Payment:** Payment shall be made by Buyer net 30 days from the date of delivery of the items purchased hereunder. Amounts not timely paid shall bear interest at the maximum rate permitted by law for each month or portion thereof that the Buyer is late in making payment. Any claims by Buyer for omissions or shortages in a shipment shall be waived unless Seller receives notice thereof within 30 days after Buyer's receipt of the shipment.

**3. Delivery:** Unless otherwise provided on the face hereof, delivery shall be made F.O.B. Seller's plant. Regardless of the method of delivery, however, risk of loss shall pass to Buyer upon Seller's delivery to a carrier. Any delivery dates shown are approximate only and Seller shall have no liability for any delays in delivery.

**4. Warranty:** Seller warrants that the items sold hereunder shall be free from defects in material or workmanship for a period of 18 months from date of shipment from Parker Hannifin Corporation. THIS WARRANTY COMPRISES THE SOLE AND ENTIRE WARRANTY PERTAINING TO ITEMS PROVIDED HEREUNDER. SELLER MAKES NO OTHER WARRANTY, GUARANTEE, OR REPRESENTATION OF ANY KIND WHATSOEVER. ALL OTHER WARRANTIES, INCLUDING BUT NOT LIMITED TO, MERCHANTABILITY AND FITNESS FOR PURPOSE, WHETHER EXPRESS, IMPLIED, OR ARISING BY OPERATION OF LAW, TRADE USAGE, OR COURSE OF DEALING ARE HEREBY DISCLAIMED.

NOTWITHSTANDING THE FOREGOING, THERE ARE NO WARRANTIES WHATSOEVER ON ITEMS BUILT OR ACQUIRED WHOLLY OR PARTIALLY, TO BUYER'S DESIGN OR SPECIFICATIONS.

**5. Limitation of Remedy:** SELLER'S LIABILITY ARISING FROM OR IN ANY WAY CONNECTED WITH THE ITEMS SOLD OR THIS CONTRACT SHALL BE LIMITED EXCLUSIVELY TO REPAIR OR REPLACEMENT OF THE ITEMS SOLD OR REFUND OF THE PURCHASE PRICE PAID BY BUYER, AT SELLER'S SOLE OPTION. IN NO EVENT SHALL SELLER BE LIABLE FOR ANY INCIDENTAL, CONSEQUENTIAL OR SPECIAL DAMAGES OF ANY KIND OR NATURE WHATSOEVER, INCLUDING BUT NOT LIMITED TO LOST PROFITS ARISING FROM OR IN ANY WAY CONNECTED WITH THIS AGREEMENT OR ITEMS SOLD HEREUNDER, WHETHER ALLEGED TO ARISE FROM BREACH OF CONTRACT, EXPRESS OR IMPLIED WARRANTY, OR IN TORT, INCLUDING WITHOUT LIMITATION, NEGLIGENCE, FAILURE TO WARN OR STRICT LIABILITY.

**6. Changes, Reschedules and Cancellations:** Buyer may request to modify the designs or specifications for the items sold hereunder as well as the quantities and delivery dates thereof, or may request to cancel all or part of this order, however, no such requested modification or cancellation shall become part of the contract between Buyer and Seller unless accepted by Seller in a written amendment to this Agreement. Acceptance of any such requested modification or cancellation shall be at Seller's discretion, and shall be upon such terms and conditions as Seller may require.

**7. Special Tooling:** A tooling charge may be imposed for any special tooling, including without limitations, dies, fixtures, molds and patterns, acquired to manufacture items sold pursuant to this contract. Such special tooling shall be and remain Seller's property notwithstanding payment of any charges by Buyer. In no event will Buyer acquire any interest in apparatus belonging to Seller which is utilized in the manufacture of the items sold hereunder, even if such apparatus has been specially converted or adapted for such manufacture and notwithstanding any

charges paid by Buyer. Unless otherwise agreed, Seller shall have the right to alter, discard or otherwise dispose of any special tooling or other property in its sole discretion at any time.

**8. Buyer's Property:** Any designs, tools, patterns, materials, drawings, confidential information or equipment furnished by Buyer, or any other items which become Buyer's property, may be considered obsolete and may be destroyed by Seller after two (2) consecutive years have elapsed without Buyer placing an order for the items which are manufactured using such property. Seller shall not be responsible for any loss or damage to such property while it is in Seller's possession or control.

**9. Taxes:** Unless otherwise indicated on the face hereof, all prices and charges are exclusive of excise, sales, use, property, occupational or like taxes which may be imposed by any taxing authority upon the manufacture, sale or delivery of the items sold hereunder. If any such taxes must be paid by Seller or if Seller is liable for the collection of such tax, the amount thereof shall be in addition to the amounts for the items sold. Buyer agrees to pay all such taxes or to reimburse Seller therefore upon receipt of its invoice. If Buyer claims exemption from any sales, use or other tax imposed by any taxing authority, Buyer shall save Seller harmless from and against any such tax, together with any interest or penalties thereon which may be assessed if the items are held to be taxable.

**10. Indemnity For Infringement of Intellectual Property Rights:** Seller shall have no liability for infringement of any patents, trademarks, copyrights, trade dress, trade secrets or similar rights except as provided in this Part 10. Seller will defend and indemnify Buyer against allegations of infringement of U.S. patents, U.S. trademarks, copyrights, trade dress and trade secrets (hereinafter "Intellectual Property Rights"). Seller will defend at its expense and will pay the cost of any settlement or damages awarded in an action brought against Buyer based on an allegation that an item sold pursuant to this contract infringes the Intellectual Property Rights of a third party. Seller's obligation to defend and indemnify Buyer is contingent on Buyer notifying Seller within ten (10) days after Buyer becomes aware of such allegations of infringement, and Seller having sole control over the defense of any allegations or actions including all negotiations for settlement or compromise. If an item sold hereunder is subject to a claim that it infringes the Intellectual Property Rights of a third party, Seller may, at its sole expense and option, procure for Buyer the right to continue using said item, replace or modify said item so as to make it noninfringing, or offer to accept return of said item and return the purchase price less a reasonable allowance for depreciation. Notwithstanding the foregoing, Seller shall have no liability for claims of infringement based on information provided by Buyer, or directed to items delivered hereunder for which the designs are specified in whole or part by Buyer, or infringements resulting from the modification, combination or use in a system of any item sold hereunder. The foregoing provisions of this Part 10 shall constitute Seller's sole and exclusive liability and Buyer's sole and exclusive remedy for infringement of Intellectual Property Rights.

If a claim is based on information provided by Buyer or if the design for an item delivered hereunder is specified in whole or in part by Buyer, Buyer shall defend and indemnify Seller for all costs, expenses or judgements resulting from any claim that such item infringes any patent, trademark, copyright, trade dress, trade secret or any similar right.

**11. Force Majeure:** Seller does not assume the risk of and shall not be liable for delay or failure to perform any of Seller's obligations by reason of circumstances beyond the reasonable control of Seller (hereinafter "Events of Force Majeure"). Events of Force Majeure shall include without limitation, accidents, acts of God, strikes or labor disputes, acts, laws, rules or regulations of any government or government agency, fires, floods, delays or failures in delivery of carriers or suppliers, shortages of materials and any other cause beyond Seller's control.

**12. Entire Agreement/Governing Law:** The terms and conditions set forth herein, together with any amendments, modifications and any different terms or conditions expressly accepted by Seller in writing, shall constitute the entire Agreement concerning the items sold, and there are no oral or other representations or agreements which pertain thereto. This Agreement shall be governed in all respects by the law of the State of Ohio. No actions arising out of sale of the items sold hereunder or this Agreement may be brought by either party more than two (2) years after the cause of action accrues.





**Parker Hannifin Corporation**  
Pneumatic Division  
8676 E. M89  
P.O. Box 901  
Richland, MI 49083 USA

Customer/Technical Service  
Tel: (269) 629-5575  
Fax: (269) 629-5385  
Web site: [www.wattsfluidair.com](http://www.wattsfluidair.com)  
E-mail: [wattsfluidair@parker.com](mailto:wattsfluidair@parker.com)